

Grizzly *Industrial, Inc.*®

MODEL G0700 10" SLIDING TABLE SAW OWNER'S MANUAL



COPYRIGHT © JULY, 2010. BY GRIZZLY INDUSTRIAL, INC.

**WARNING: NO PORTION OF THIS MANUAL MAY BE REPRODUCED IN ANY SHAPE
OR FORM WITHOUT THE WRITTEN APPROVAL OF GRIZZLY INDUSTRIAL, INC.
(FOR MACHINES MANUFACTURED SINCE 8/09) #TR12474 PRINTED IN TAIWAN**



WARNING!

This manual provides critical safety instructions on the proper setup, operation, maintenance and service of this machine/equipment.

Failure to read, understand and follow the instructions given in this manual may result in serious personal injury, including amputation, electrocution or death.

The owner of this machine/equipment is solely responsible for its safe use. This responsibility includes but is not limited to proper installation in a safe environment, personnel training and usage authorization, proper inspection and maintenance, manual availability and comprehension, application of safety devices, blade/cutter integrity, and the usage of personal protective equipment.

The manufacturer will not be held liable for injury or property damage from negligence, improper training, machine modifications or misuse.



WARNING!

Some dust created by power sanding, sawing, grinding, drilling, and other construction activities contains chemicals known to the State of California to cause cancer, birth defects or other reproductive harm. Some examples of these chemicals are:

- **Lead from lead-based paints.**
- **Crystalline silica from bricks, cement and other masonry products.**
- **Arsenic and chromium from chemically-treated lumber.**

Your risk from these exposures varies, depending on how often you do this type of work. To reduce your exposure to these chemicals: Work in a well ventilated area, and work with approved safety equipment, such as those dust masks that are specially designed to filter out microscopic particles.

Table of Contents

INTRODUCTION	2	SECTION 5: SHOP MADE SAFETY ACCESSORIES	47
Manual Accuracy	2	Featherboards.....	47
Contact Info.....	2	Push Sticks	50
Machine Description	2	Push Blocks	51
Identification.....	3	Zero-Clearance Insert.....	52
Machine Data Sheet	4	Outfeed Table	53
SECTION 1: SAFETY	7	Narrow-Rip Auxiliary Fence & Push Block ..	54
Safety Instructions for Machinery	7	SECTION 6: AFTERMARKET ACCESSORIES FROM GRIZZLY	56
Additional Safety for Sliding Table Saws.....	9	SECTION 7: MAINTENANCE	58
Preventing Kickback	10	Schedule	58
Protecting Yourself From Kickback.....	10	Cleaning.....	58
Glossary of Terms	11	Unpainted Cast Iron.....	58
SECTION 2: POWER SUPPLY	12	Lubrication	59
SECTION 3: SETUP	14	SECTION 8: SERVICE	60
Setup Safety	14	Troubleshooting	60
Unpacking	14	Belt Replacement.....	62
Items Needed For Setup.....	14	Blade Tilt Calibration.....	63
Hardware Recognition Chart	15	Sliding Table Parallel Adjustment.....	64
Inventory	16	Sliding Table Adjustment	65
Cleanup.....	18	Squaring Miter Fence to Blade	65
Site Considerations.....	19	Adjusting Riving Knife Mounting Block.....	66
Moving & Placing Table Saw	20	SECTION 9: WIRING	67
Assembly & Setup	21	Wiring Safety Instructions	67
Power Connection.....	27	Wiring Diagrams	68
Test Run	28	Electrical Components.....	69
SECTION 4: OPERATIONS	29	SECTION 10: PARTS	70
Operation Overview	29	Cabinet.....	70
Workpiece Inspection.....	30	Handwheels	72
Non-Through & Through Cuts	30	Main Motor	73
Blade Guard & Riving Knife.....	31	Blade Housing.....	75
Blade Requirements	33	Tables	76
Blade Selection	33	Fence	78
Changing Main Blade	35	Miter Gauge	80
Changing/Adjusting Scoring Blade	36	Labels & Miscellaneous	81
Rip Cutting	37	WARRANTY AND RETURNS	85
Crosscutting	39		
Miter Cutting.....	40		
Dado Cutting.....	41		
Rabbet Cutting.....	43		
Resawing	45		

INTRODUCTION

Manual Accuracy

We are proud to offer this manual with your new machine! We've made every effort to be exact with the instructions, specifications, drawings, and photographs of the machine we used when writing this manual. However, sometimes we still make an occasional mistake.

Also, owing to our policy of continuous improvement, **your machine may not exactly match the manual**. If you find this to be the case, and the difference between the manual and machine leaves you in doubt, check our website for the latest manual update or call technical support for help.

Before calling, find the manufacture date of your machine by looking at the date stamped into the machine ID label (see below). This will help us determine if the manual version you received matches the manufacture date of your machine.

		MODEL GXXXX MACHINE NAME	
SPECIFICATIONS		▲ WARNING!	
Motor:		ing this machine: operation. s and respirator. sted/setup and suit before starting.	
Specification:			
Specification:			
Specification:			
Weight:			
	Date		
	Serial Number		
Manufactured for Grizzly in Taiwan			
4. make sure the motor has stopped and disconnect power before adjustments, maintenance, or service.			
5. DO NOT expose to rain or dampness.			
6. DO NOT modify this machine in any way.			
7. DO NOT remove safety guards.			
8. Never leave machine running unattended.			
9. DO NOT operate under the influence of drugs or alcohol.			
10. Maintain machine carefully to prevent accidents.			

For your convenience, we post all available manuals and manual updates for free on our website at www.grizzly.com. Any updates to your model of machine will be reflected in these documents as soon as they are complete.

Contact Info

We stand behind our machines. If you have any service questions, parts requests or general questions about the machine, please call or write us at the location listed below.

Grizzly Industrial, Inc.
1203 Lycoming Mall Circle
Muncy, PA 17756
Phone: (570) 546-9663
E-Mail: techsupport@grizzly.com

We want your feedback on this manual. If you can take the time, please email or write to us at the address below and tell us how we did:

Grizzly Industrial, Inc.
c/o Technical Documentation Manager
P.O. Box 2069
Bellingham, WA 98227-2069
Email: manuals@grizzly.com

Machine Description

The Model G0700 is designed as an alternative option to a traditional cabinet saw. This saw is capable of both through and non-through cutting operations, similar to a traditional cabinet saw, but has a sliding table available to assist with cross-cuts or angled cuts that would otherwise require a jig or crosscut sled to cut safely.

A scoring blade is included with the Model G0700. It may or may not be used, depending on if the workpiece is faced with laminate, melamine, or other solid surface material, or if tear-out free cuts are required. If the scoring blade is not needed for cutting operations, it can be lowered under the table so it will stay sharp for later operations.

In order to produce accurate results, the sliding table must move parallel to the blade and the scoring blade must be aligned with the main blade.



Identification

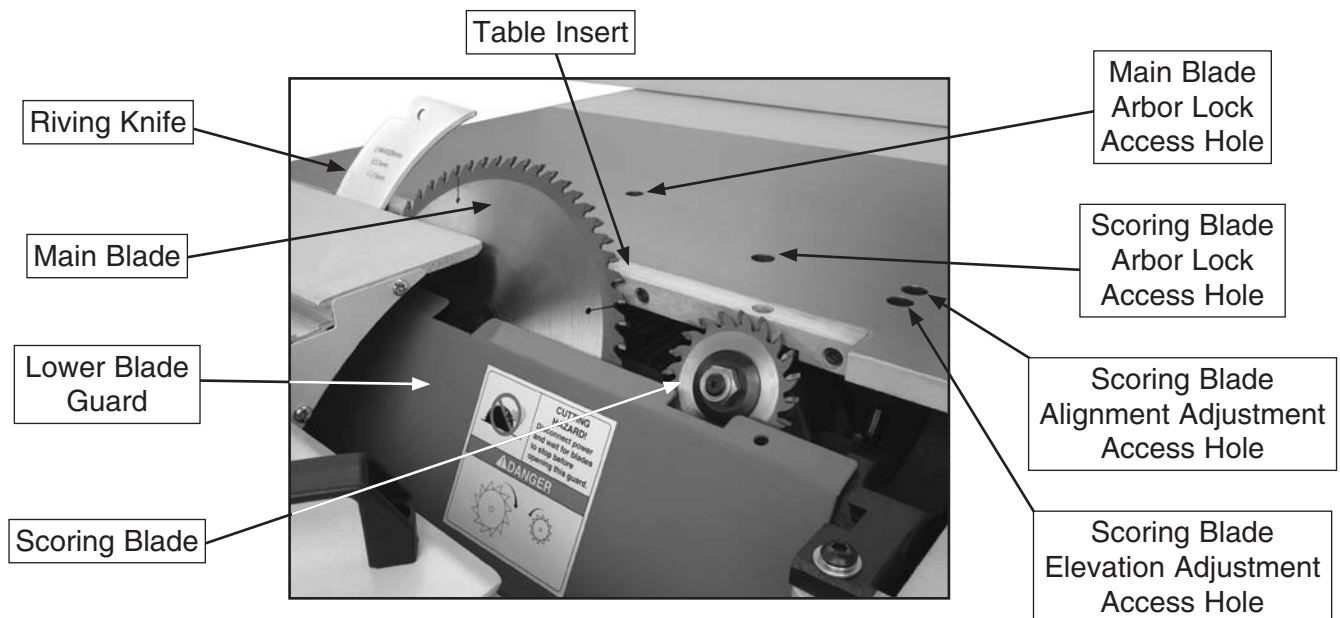
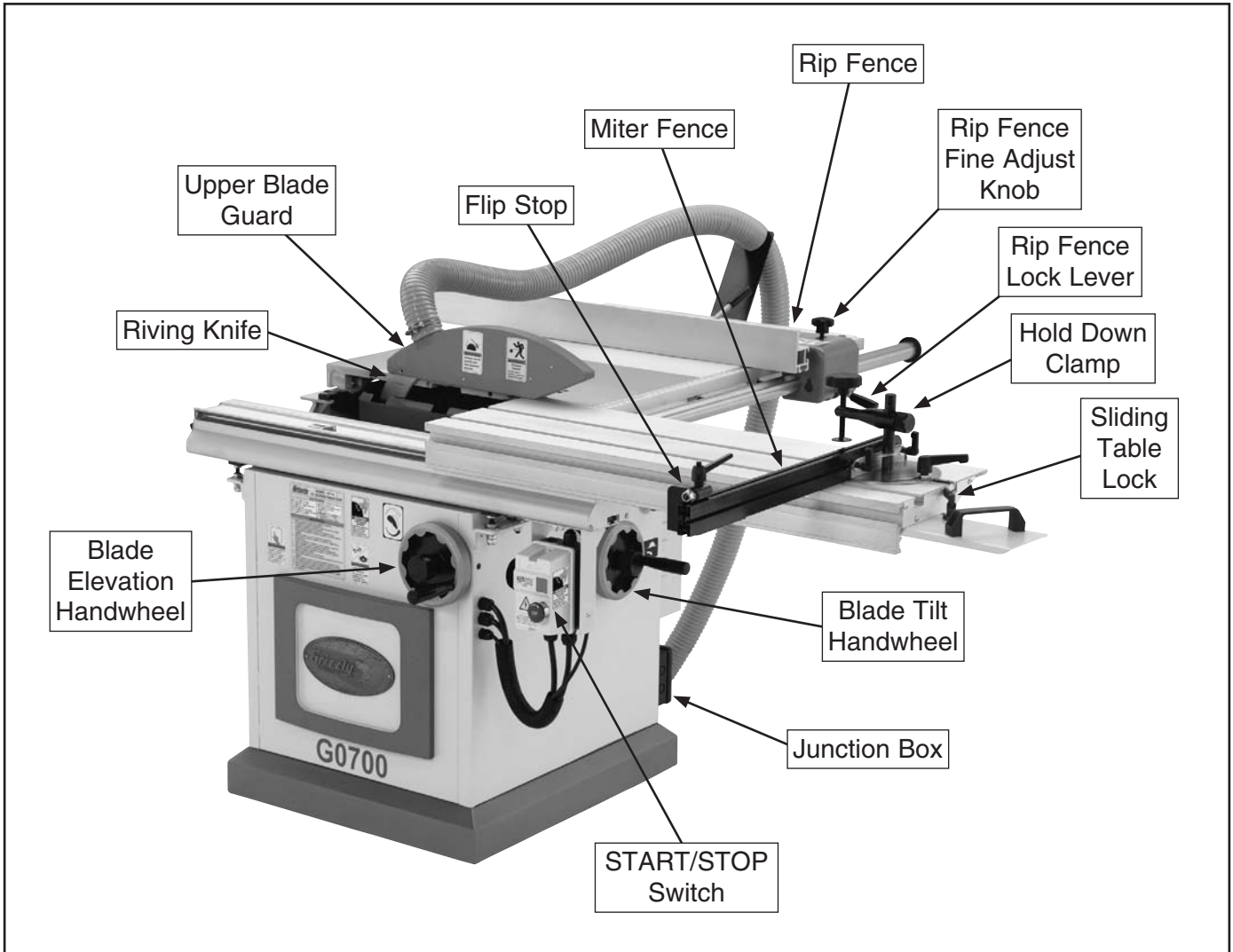



MACHINE DATA SHEET

Customer Service #: (570) 546-9663 · To Order Call: (800) 523-4777 · Fax #: (800) 438-5901

MODEL G0700 10" SLIDING TABLESAW WITH SCORING

Product Dimensions:

Weight..... 473 lbs.
 Length/Width/Height..... 47 x 71 x 48 in.
 Foot Print (Length/Width)..... 27-1/2 x 25-1/2 in.

Shipping Dimensions:

Type..... Wood
 Content..... Machine
 Weight..... 572 lbs.
 Length/Width/Height..... 46 x 42 x 44 in.

Electrical:

Power Requirement..... 220V, Single-Phase, 60 Hz
 Minimum Circuit Size..... 30A
 Switch..... Magnetic Switch w/Thermal Overload
 Switch Voltage..... 220V
 Plug Included..... No
 Recommended Plug/Outlet Type..... NEMA L6-30

Motors:

Main

Type..... TEFC Capacitor Start Induction
 Horsepower..... 5 HP
 Voltage..... 220V
 Phase..... Single-Phase
 Amps..... 22A
 Speed..... 3450 RPM
 Cycle..... 60 Hz
 Number Of Speeds..... 1
 Power Transfer V-Belt
 Bearings..... Shielded and Permanently Sealed

Main Specifications:

Operation Information

Main Blade Size..... 10 in.
 Main Arbor Size..... 5/8 in.
 Scoring Blade Size..... 3-1/8 in.
 Scoring Blade Arbor Size..... 22 mm
 Maximum Width of Dado..... 13/16 in.
 Main Blade Tilt..... 0-45 deg.
 Main Blade Speed..... 4000 RPM
 Scoring Blade Tilt..... 0-45 deg.
 Scoring Blade Speed..... 8000 RPM



Cutting Capacities

Max Depth Of Cut At 90D.....	3-1/8 in.
Max Depth Of Cut At 45D.....	2-1/4 in.
Table With Rip Fence Max Cut Width.....	34 in.
Sliding Table With Cross Fence Max Cut Width.....	27-1/2 in.
Sliding Table With Cross Fence Max Cut Length.....	39-3/8 in.
Miter Fence Cut Width At 45D.....	38 in.

Table Information

Table Size Length.....	27 in.
Table Size Width.....	14-3/4 in.
Table Size With Ext Wings Length.....	27 in.
Table Size With Ext Wings Width.....	39-3/4 in.
Sliding Table Length.....	39-3/8 in.
Sliding Table Width.....	12-1/4 in.

Construction Materials

Table Construction.....	Cast Iron
Sliding Table Construction.....	Aluminum
Base Construction.....	Cast Iron
Cabinet Construction.....	Steel
Trunnions Construction.....	Cast Iron
Rollers Construction.....	Steel
Fence Assembly Construction.....	Extruded Aluminum & Cast Iron
Rails Construction.....	Hardened Steel
Guard Construction.....	Plastic
Spindle Bearing Type.....	Lubricated & Permanently Sealed Ball Bearings
Paint.....	Powder Coated

Other Related Information

No Of Dust Ports.....	2
Dust Port Size.....	2-1/2, 4 in.

Other Specifications:

Country Of Origin	Taiwan
Warranty	1 Year
Serial Number Location	Machine ID Label on Side of Machine
Assembly Time	1 Hour
Sound Rating	80 dB

Features:

- Blade guard with 2-1/2" dust port
- 4" main dust port
- Adjustable scoring blade
- Adjustable riving knife
- Single-lever locking miter fence





SLIDING TABLE SAW CAPACITIES

Customer Service #: (570) 546-9663 • To Order Call: (800) 523-4777 • Fax #: (800) 438-5901

MODEL G0700 10" SLIDING TABLE SAW

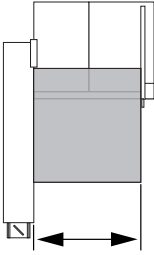
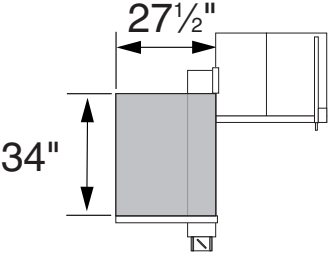
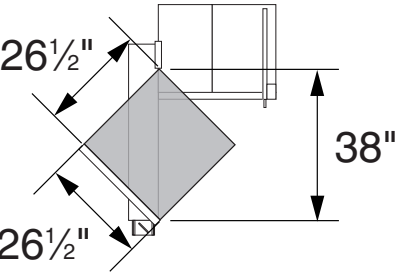
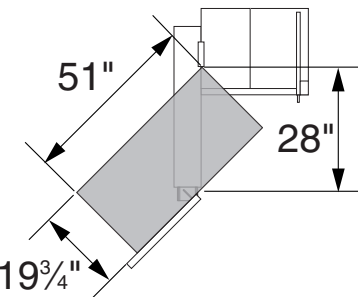
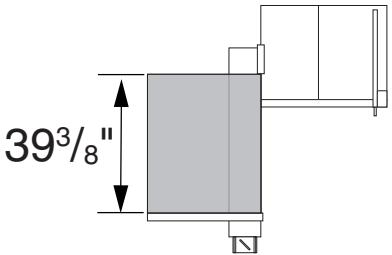
 <p>Ripping Width 34"</p>	 <p>Miter Cut 90° w/Miter Fence 27 1/2" 34"</p>
 <p>Miter Cut +45° w/Miter Fence 26 1/2" 38"</p>	 <p>Miter Cut -45° w/Miter Fence 51" 28" 19 3/4"</p>
 <p>Maximum Cutting Length (w/o Scoring Blade) 39 3/8"</p>	



SECTION 1: SAFETY

WARNING

For Your Own Safety, Read Instruction Manual Before Operating this Machine

The purpose of safety symbols is to attract your attention to possible hazardous conditions. This manual uses a series of symbols and signal words intended to convey the level of importance of the safety messages. The progression of symbols is described below. Remember that safety messages by themselves do not eliminate danger and are not a substitute for proper accident prevention measures.

 **DANGER** Indicates an imminently hazardous situation which, if not avoided, **WILL** result in death or serious injury.

 **WARNING** Indicates a potentially hazardous situation which, if not avoided, **COULD** result in death or serious injury.

 **CAUTION** Indicates a potentially hazardous situation which, if not avoided, **MAY** result in minor or moderate injury. It may also be used to alert against unsafe practices.

NOTICE This symbol is used to alert the user to useful information about proper operation of the machine.

WARNING

Safety Instructions for Machinery

OWNER'S MANUAL. Read and understand this owner's manual **BEFORE** using machine. Untrained users can be seriously hurt.

EYE PROTECTION. Always wear ANSI-approved safety glasses or a face shield when operating or observing machinery to reduce the risk of eye injury or blindness from flying particles. Everyday eyeglasses are not approved safety glasses.

HAZARDOUS DUST. Dust created while using machinery may cause cancer, birth defects, or long-term respiratory damage. Be aware of dust hazards associated with each workpiece material, and always wear a NIOSH-approved respirator to reduce your risk.

WEARING PROPER APPAREL. Do not wear clothing, apparel, or jewelry that can become entangled in moving parts. Always tie back or cover long hair. Wear non-slip footwear to avoid accidental slips which could cause a loss of workpiece control.

HEARING PROTECTION. Always wear hearing protection when operating or observing loud machinery. Extended exposure to this noise without hearing protection can cause permanent hearing loss.

MENTAL ALERTNESS. Be mentally alert when running machinery. Never operate under the influence of drugs or alcohol, when tired, or when distracted.



WARNING

DISCONNECTING POWER SUPPLY. Always disconnect machine from power supply before servicing, adjusting, or changing cutting tools (bits, blades, cutters, etc.). Make sure switch is in OFF position before reconnecting to avoid an unexpected or unintentional start.

APPROVED OPERATION. Untrained operators can be seriously hurt by machinery. Only allow trained or properly supervised people to use machine. When machine is not being used, disconnect power, remove switch keys, or lock-out machine to prevent unauthorized use—especially around children. Make workshop kid proof!

DANGEROUS ENVIRONMENTS. Do not use machinery in wet or rainy locations, cluttered areas, around flammables, or in poorly-lit areas. Keep work area clean, dry, and well-lighted to minimize risk of injury.

ONLY USE AS INTENDED. Only use machine for its intended purpose. Never modify or alter machine for a purpose not intended by the manufacturer or serious injury may result!

USE RECOMMENDED ACCESSORIES. Consult this owner's manual or the manufacturer for recommended accessories. Using improper accessories will increase the risk of serious injury.

CHILDREN & BYSTANDERS. Keep children and bystanders a safe distance away from work area. Stop using machine if children or bystanders become a distraction.

REMOVE ADJUSTING TOOLS. Never leave adjustment tools, chuck keys, wrenches, etc. in or on machine—especially near moving parts. Verify removal before starting!

SECURING WORKPIECE. When required, use clamps or vises to secure workpiece. A secured workpiece protects hands and frees both of them to operate the machine.

FEED DIRECTION. Unless otherwise noted, feed work against the rotation of blades or cutters. Feeding in the same direction of rotation may pull your hand into the cut.

FORCING MACHINERY. Do not force machine. It will do the job safer and better at the rate for which it was designed.

GUARDS & COVERS. Guards and covers can protect you from accidental contact with moving parts or flying debris. Make sure they are properly installed, undamaged, and working correctly before using machine.

NEVER STAND ON MACHINE. Serious injury or accidental contact with cutting tool may occur if machine is tipped. Machine may be damaged.

STABLE MACHINE. Unexpected movement during operations greatly increases the risk of injury and loss of control. Verify machines are stable/secure and mobile bases (if used) are locked before starting.

AWKWARD POSITIONS. Keep proper footing and balance at all times when operating machine. Do not overreach! Avoid awkward hand positions that make workpiece control difficult or increase the risk of accidental injury.

UNATTENDED OPERATION. Never leave machine running while unattended. Turn machine **OFF** and ensure all moving parts completely stop before walking away.

MAINTAIN WITH CARE. Follow all maintenance instructions and lubrication schedules to keep machine in good working condition. An improperly maintained machine may increase the risk of serious injury.

CHECK DAMAGED PARTS. Regularly inspect machine for damaged parts, loose bolts, mis-adjusted or mis-aligned parts, binding, or any other conditions that may affect safe operation. Always repair or replace damaged or mis-adjusted parts before operating machine.

EXPERIENCING DIFFICULTIES. If at any time you are experiencing difficulties performing the intended operation, stop using the machine! Contact our Technical Support Department at (570) 546-9663.



WARNING

Additional Safety for Sliding Table Saws

BLADE GUARD/RIVING KNIFE. To reduce the risk of kickback, always make sure the riving knife and the blade guard are properly installed during all cutting operations.

KICKBACK. Kickback happens when the workpiece is thrown back toward the operator at a high rate of speed. Until you have a clear understanding of kickback, how it occurs, and how to prevent it, DO NOT operate this saw!

WORKPIECE CONTROL. If the workpiece should unexpectedly move or bind the blade, kickback could occur. Always make sure the workpiece is placed in a stable position on the table and is supported by either the rip fence or the miter fence during cutting operations. *Never back a workpiece out of a cut!*

PUSH STICKS/BLOCKS. When ripping narrow stock, there is a risk of your hands contacting the spinning blade resulting in serious injury. Always use push sticks/blocks when cutting narrow stock to keep hands clear of the blade.

OPERATOR POSITION. If kickback occurs, the blade will eject the workpiece into the cutting path. Never stand in-line with the cutting path of the blade during operation.

AWKWARD POSITIONS. Avoid awkward body and hand positions where a sudden slip could cause your hands to hit the spinning blade.

RIVING KNIFE ALIGNMENT. If the riving knife is not aligned with the saw blade, the workpiece could bind and cause kickback. Always make sure the riving knife is in proper alignment with the saw blade.

REACHING OVER SAW BLADE. Never reach behind or over the blade with either hand while the saw is running. *If kickback occurs while reaching over the blade, hands or arms will be pulled into the blade and may be amputated!*

REMOVING WORKPIECES. To avoid accidental contact with the spinning blade, always turn the saw OFF and wait until the blade is completely stopped before removing cut-offs. Use a push stick to keep hands away from the blade.

BLADE HEIGHT. Make sure the blade is adjusted to the correct height above the workpiece to prevent the blade from aggressively grabbing the workpiece and kicking it back toward the operator.

DAMAGED SAW BLADES. A saw blade that is damaged or bent can cause kickback during operations. If you have any doubt about the condition of the saw blade, DO NOT use it!

SAFE WORKPIECES. Cutting workpieces that are bent, warped, or curved, or cutting material not intended for this saw, increases the risk of kickback.

WARNING

Like all machines there is danger associated with this machine. Accidents are frequently caused by lack of familiarity or failure to pay attention. Use this machine with respect and caution to lessen the possibility of operator injury. If normal safety precautions are overlooked or ignored, serious personal injury may occur.

CAUTION

No list of safety guidelines can be complete. Every shop environment is different. Always consider safety first, as it applies to your individual working conditions. Use this and other machinery with caution and respect. Failure to do so could result in serious personal injury, damage to equipment, or poor work results.



Preventing Kickback

Below are ways to avoid the most common causes of kickback:

- Only cut workpieces with at least one smooth and straight edge. DO NOT cut excessively warped, cupped or twisted wood. If the workpiece warpage is questionable, always choose another workpiece.
- Never attempt freehand cuts. If the workpiece is not fed parallel with the blade, a kickback will likely occur. Always use the rip fence or crosscut fence to support the workpiece.
- Make sure the riving knife is aligned with the blade. A misaligned riving knife can cause the workpiece to catch or bind, increasing the chance of kickback. If you think that your riving knife is not aligned with the blade, check it immediately!
- Ensure that your table slides parallel with the blade; otherwise, the chances of kickback are greatly increased. Take the time to check and adjust the sliding table to be parallel with the blade.
- Do not remove the riving knife. The riving knife maintains the kerf in the workpiece, reducing the chance of kickback.
- Keep the blade guard installed and working correctly for all through cuts.
- Feed cuts through to completion. Anytime you stop feeding a workpiece in the middle of a cut, the chance of kickback is increased.
- Never move the workpiece backwards while cutting or try to back it out of a cut while the blade is moving. If you cannot complete a cut for some reason, stop the saw motor and allow the blade to completely stop moving before backing the workpiece out. Promptly fix the condition that prevented you from completing the cut, before starting the saw again.

Protecting Yourself From Kickback

Even if you know how to prevent kickback, it may still happen. Here are some tips to protect yourself if kickback DOES occur:

- Stand to the side of the blade during every cut. If a kickback does occur, the thrown workpiece usually travels directly in front of the blade.
- Wear safety glasses or a face shield. In the event of a kickback, your eyes and face are the most vulnerable part of your body.
- Never, for any reason, place your hand behind the blade. Should kickback occur, your hand will be pulled into the blade, which could cause amputation.
- Use a push stick to keep your hands farther away from the moving blade. If a kickback occurs, the push stick will most likely take the damage that your hand would have received.
- Use featherboards or anti-kickback devices to assist with feeding and prevent or slow down kickback.

WARNING

Statistics show that most common accidents among table saw users can be linked to kickback. Kickback is typically defined as the high-speed ejection of stock from the table saw toward its operator. In addition to the danger of the operator or others in the area being struck by the flying stock, it is often the case that the operator's hands are pulled into the blade during the kickback.



Glossary of Terms

The following is a list of common definitions, terms and phrases used throughout this manual as they relate to this table saw and woodworking in general. Become familiar with these terms for assembling, adjusting or operating this machine.

Arbor: The metal shaft on which the blade is mounted.

Bevel Edge Cut: A cut made along the edge of a workpiece with the saw blade tilted between 0° and 45°. Refer to **Page 63** for more details.

Blade Guard Assembly: A safety device that mounts over the saw blade to help prevent accidental contact with the saw blade and to contain flying chips and dust. Refer to **Page 31** for more details.

Crosscut: Cutting operation in which the miter gauge is used to hold the workpiece while it is cut across its shortest width. Refer to **Page 39** for more details.

Dado Blade: Blade or set of blades that are used to cut grooves and rabbets.

Dado Cut: Cutting operation that uses a dado blade to cut a flat bottomed groove into the face of the workpiece. Refer to **Page 41** for more details.

Featherboard: Safety device used to keep the workpiece held firmly against the rip fence or table surface. Refer to **Page 47** for more details.

Kerf: The resulting cut or gap in the workpiece after the saw blade passes through during a cutting operation.

Kickback: An event in which the spinning blade ejects the workpiece toward the front of the saw at a high rate of speed.

Non-Through Cut: A cut in which the blade does not cut through the top of the workpiece. Refer to **Page 30** for more details.

Parallel: Being an equal distance apart at every point along two given lines or planes (i.e. the rip fence face is parallel to the face of the saw blade).

Perpendicular: Lines or planes that intersect and form right angles (i.e. the blade is perpendicular to the table surface).

Push Stick: Safety device used to push the workpiece through a cutting operation. Used most often when rip cutting thin workpieces. Refer to **Page 50** for more details.

Rabbet: Cutting operation that creates an L-shaped channel along the edge of the workpiece. Refer to **Page 43** for more details.

Rip Cut: Cutting operation in which the rip fence is used to cut across the widest width of the workpiece. Refer to **Page 37** for more details.

Riving Knife: Curved metal plate located behind the blade. Maintains kerf opening in wood when performing a cutting operation. Acts as a barrier behind blade to shield hands from being pulled into the blade if a kickback occurs. Refer to **Page 31** for more details.

Straightedge: A tool used to check the flatness, parallelism, or consistency of a surface(s).

Thin Kerf Blade: A blade with a kerf or thickness that is thinner than a standard blade cannot be used on this saw.

Through Cut: A cut in which the blade cuts completely through the workpiece (refer to **Page 30**).



SECTION 2: POWER SUPPLY

Availability

Before installing the machine, consider the availability and proximity of the required power supply circuit. If an existing circuit does not meet the requirements for this machine, a new circuit must be installed. To minimize the risk of electrocution, fire, or equipment damage, installation work and electrical wiring must be done by a qualified electrician in accordance with all applicable codes and standards.

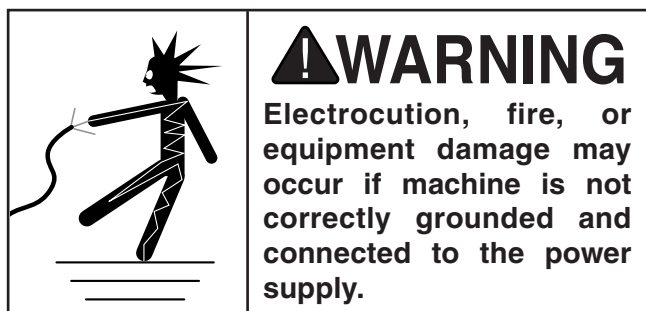

Full-Load Current Rating

The full-load current rating is the amperage a machine draws at 100% of the rated output power. On machines with multiple motors, this is the amperage drawn by the largest motor or sum of all motors and electrical devices that might operate at one time during normal operations.

Full-Load Current Rating at 220V 22 Amps

The full-load current is not the maximum amount of amps that the machine will draw. If the machine is overloaded, it will draw additional amps beyond the full-load rating.

If the machine is overloaded for a sufficient length of time, damage, overheating, or fire may result—especially if connected to an undersized circuit. To reduce the risk of these hazards, avoid overloading the machine during operation and make sure it is connected to a power supply circuit that meets the requirements in the following section.

Circuit Requirements for 220V

This machine is prewired to operate on a 220V power supply circuit that has a verified ground and meets the following requirements:

Nominal Voltage 220V/240V
Cycle 60 Hz
Phase Single-Phase
Circuit Rating 30 Amps
Plug/Receptacle NEMA L6-30
Cord 3-Wire, 10 AWG, 300VAC, “S”-Type

A power supply circuit includes all electrical equipment between the main breaker box or fuse panel in your building and the incoming power connections at the machine. This circuit must be sized to safely handle the full-load current drawn from the machine for an extended period of time.



Note: *The circuit requirements listed in this manual apply to a dedicated circuit—where only one machine will be running at a time. If this machine will be connected to a shared circuit where multiple machines will be running at the same time, consult a qualified electrician to ensure that the circuit is properly sized for safe operation.*



Grounding Instructions

In the event of certain types of malfunctions or breakdowns, grounding provides a path of least resistance for electric current—in order to reduce the risk of electric shock.

Improper connection of the equipment-grounding wire can result in a risk of electric shock. The wire with green insulation (with or without yellow stripes) is the equipment-grounding wire. If repair or replacement of the power cord or plug is necessary, do not connect the equipment-grounding wire to a live (current carrying) terminal.

Check with a qualified electrician or service personnel if you do not understand these grounding requirements, or if you are in doubt about whether the tool is properly grounded. If you ever notice that a cord or plug is damaged or worn, disconnect it from power, and immediately replace it with a new one.

The power cord and plug specified under “Circuit Requirements for 220V” on the previous page has an equipment-grounding wire and a grounding prong. The plug must only be inserted into a matching receptacle (outlet) that is properly installed and grounded in accordance with all local codes and ordinances (see figure below).

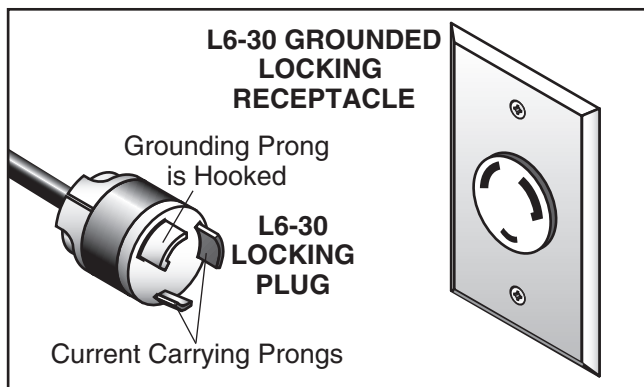

Figure 1. Typical L6-30 plug and receptacle.

!WARNING

Serious injury could occur if you connect the machine to power before completing the setup process. DO NOT connect to power until instructed later in this manual.

Extension Cords

We do not recommend using an extension cord with this machine. If you must use an extension cord, only use it if absolutely necessary and only on a temporary basis.

Extension cords cause voltage drop, which may damage electrical components and shorten motor life. Voltage drop increases as the extension cord size gets longer and the gauge size gets smaller (higher gauge numbers indicate smaller sizes).

Any extension cord used with this machine must contain a ground wire, match the required plug and receptacle, and meet the following requirements:

Minimum Gauge Size10 AWG
Maximum Length (Shorter is Better).....50 ft.



SECTION 3: SETUP

Setup Safety

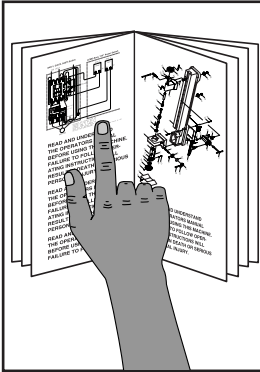

!WARNING
 This machine presents serious injury hazards to untrained users. Read through this entire manual to become familiar with the controls and operations before starting the machine!



!WARNING
 Wear safety glasses during the entire set up process!

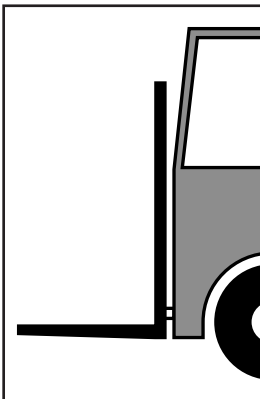

!WARNING
 This machine weighs almost 600 lbs. in the box. Serious injury may occur if safe moving methods are not followed. Get help lifting heavy parts during assembly and use a forklift to move the machine.

Unpacking

The Model G0700 was carefully packed when it left our warehouse. If you discover the machine is damaged after you have signed for delivery, *please immediately call Customer Service at (570) 546-9663 for advice.*

Save the containers and all packing materials for possible inspection by the carrier or its agent. *Otherwise, filing a freight claim can be difficult.*

When you are completely satisfied with the condition of your shipment, you should inventory the contents.

Items Needed For Setup

The following items are needed to complete the set up process, but are not included with your machine:

Description	Qty
• Safety Glasses (for each person)	1
• Forklift.....	1
• Lifting Straps	2
• Strong People for Lifting/Moving.....	2
• An Electrician	1
• Straightedge 4' (or longer)	1
• Hex Wrenches 3, 4, 5, 6, 8mm	1 Each



Hardware Recognition Chart

USE THIS CHART TO MATCH UP HARDWARE DURING THE ASSEMBLY PROCESS.

MEASURE BOLT DIAMETER BY PLACING INSIDE CIRCLE

- #10
- 1/4"
- 5/16"
- 3/8"
- 7/16"
- 1/2"

- 4mm
- 6mm
- 8mm
- 10mm
- 12mm
- 16mm

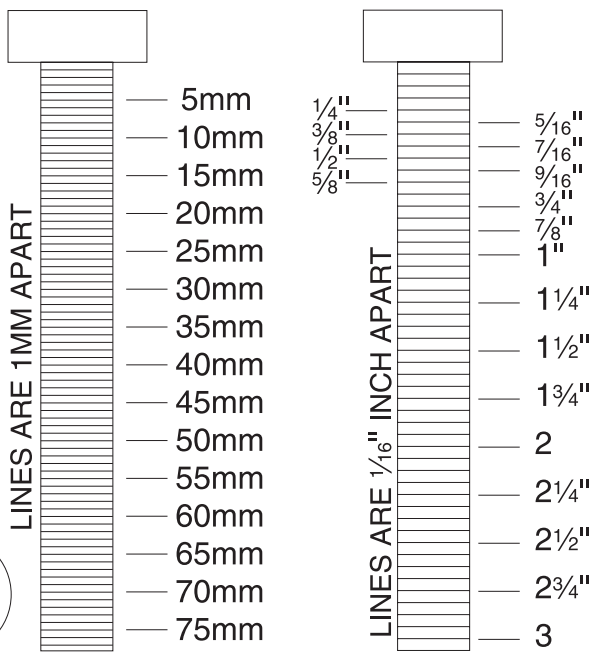
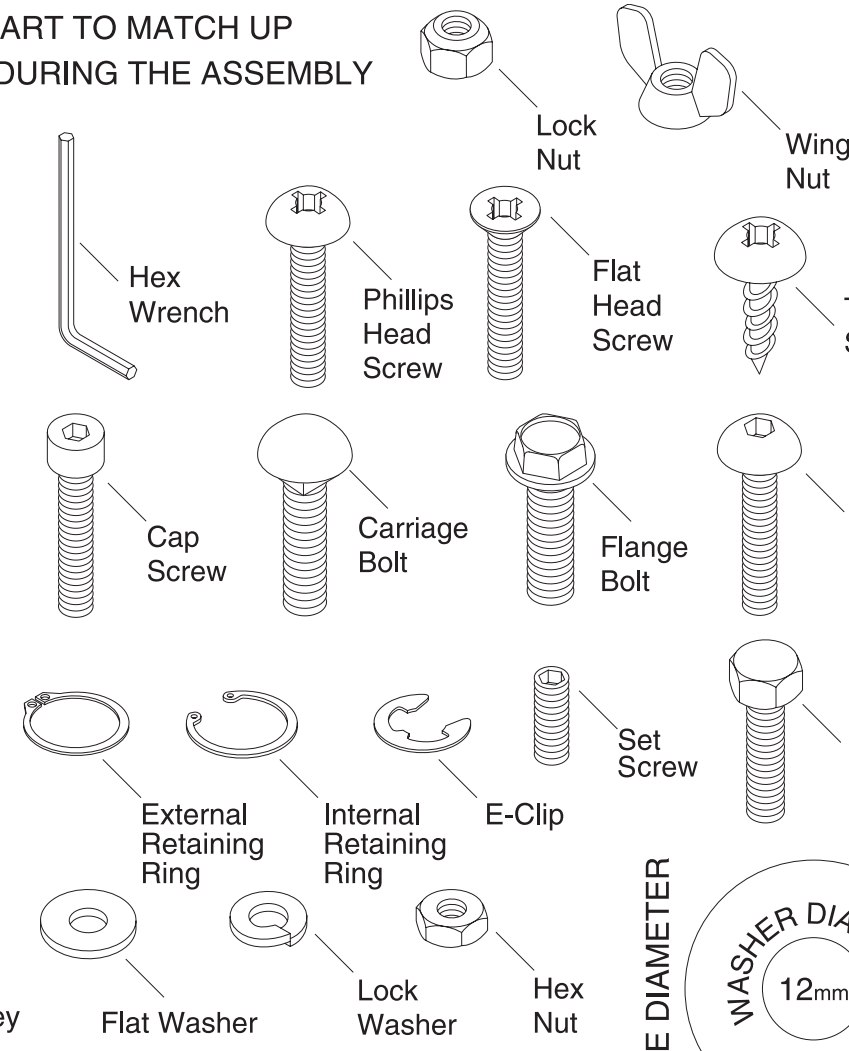

WASHERS ARE MEASURED BY THE INSIDE DIAMETER

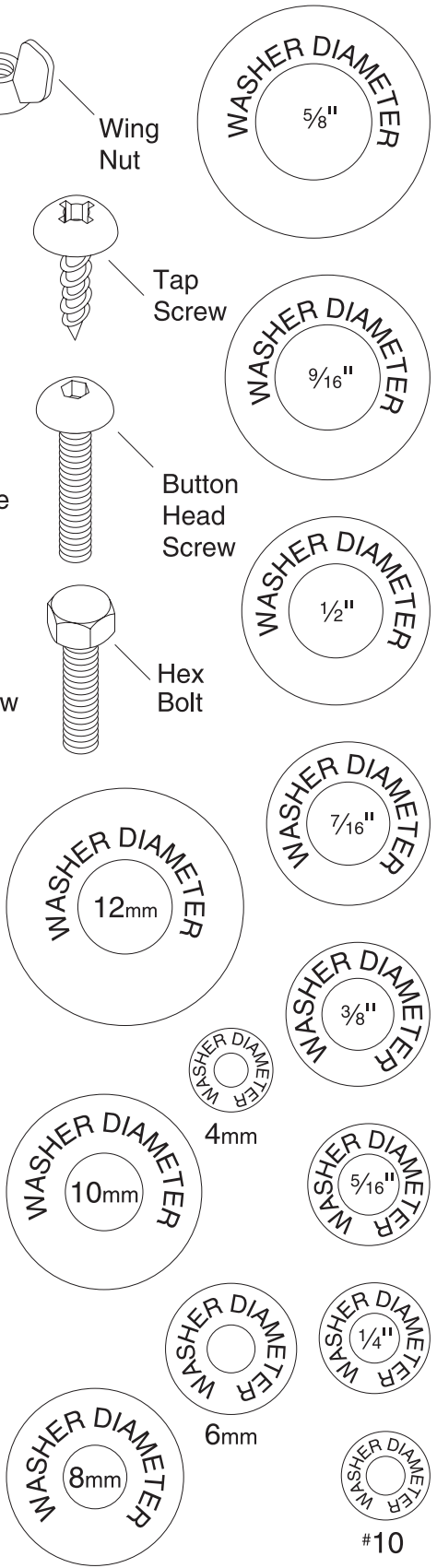

Inventory

After all the parts have been removed from the boxes in the crate, you should have the items listed below.

If any nonproprietary parts are missing (e.g. a nut or a washer), we will gladly replace them; or for the sake of expediency, replacements can be obtained at your local hardware store.

Item: (Figure 2)	Qty
A. Table Saw.....	1

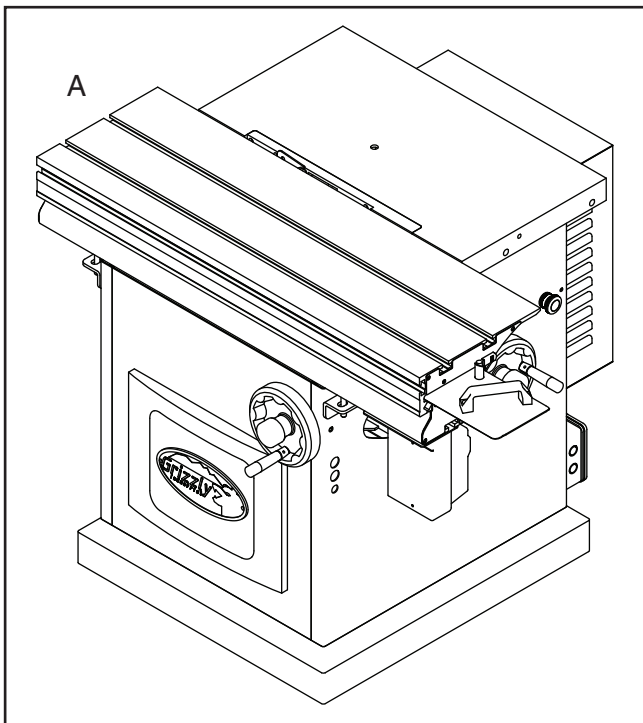

Figure 2. Table saw base unit.

Item: (Figure 3)	Qty
B. Extension Table.....	1
C. Hose Support	1
D. Dust Hose 2½".....	1
E. Hose Clamps 2½".....	2

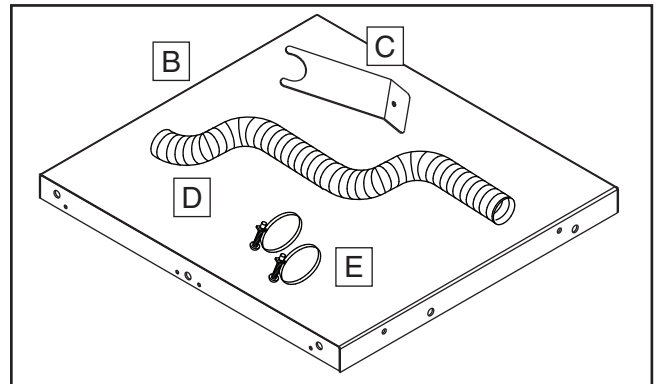

Figure 3. Extension table & dust hose components.

Item: (Figure 4)	Qty
F. Rip Fence Round Rail Assembly	1
G. Rip Fence Scale.....	1
H. Rip Fence.....	1
I. Rip Fence Base.....	1
J. Rip Fence Handles.....	2

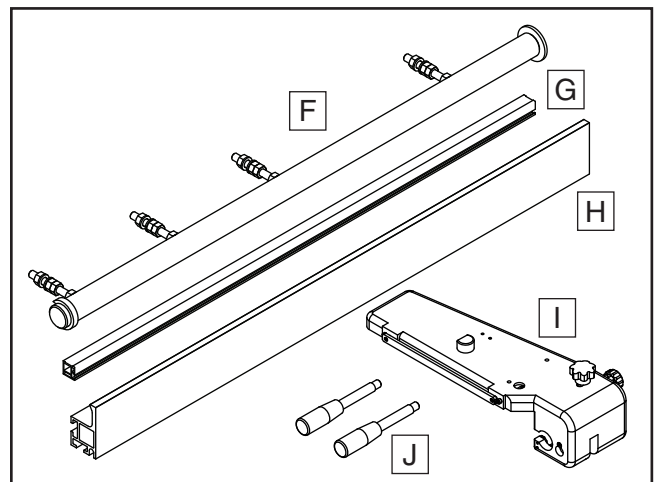

Figure 4. Rip fence components.



Item: (Figure 5)	Qty
K. Push Handle Assembly w/Lock.....	1
L. Miter Gauge Assembly w/Flip Stop.....	1
M. Push Stick	1
N. Blade Guard Assembly	1
O. Riving Knife	1
P. Arbor Lock Tool	1
Q. Wrench 17mm	1
R. Wrench 19/22mm	1
S. Scoring Blade.....	1
T. Main Blade	1

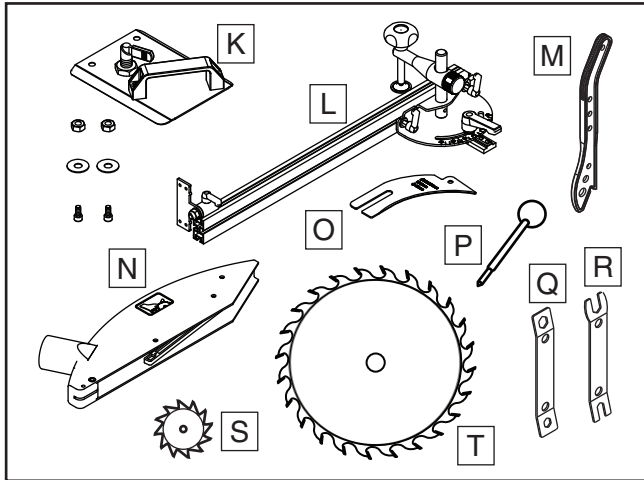

Figure 5. Miscellaneous components.

Fasteners (Grouped by Usage)	Qty
Cap Screws M10-1.5 x 25 (Ext. Table).....	5
Flat Washers 10mm (Ext. Table)	5
Lock Washers 10mm (Ext. Table).....	6
Set Screws M8-1.25 x 25 (Ext. Table)	6
Hex Nuts M8-1.25 (Ext. Table).....	6
Hex Bolts M6-1 x 16 (Fence Scale)	2
Hex Bolt M6-1 x 25 (Fence Scale).....	1
Flat Washers 6mm (Fence Scale).....	3
Lock Washers 6mm (Fence Scale).....	3
Hex Nuts M6-1 (Fence Scale).....	3
Cap Screws M5-.8 x 12 (Switch).....	2
Lock Washers 5mm (Switch)	2
Cap Screw M10-1.5 x 25 (Hose Support)	1
Flat Washers 10mm (Hose Support).....	2
Lock Washer 10mm (Hose Support).....	1
Hex Nut M10-1.5 (Hose Support).....	1



Cleanup

The unpainted surfaces of your machine are coated with a heavy-duty rust preventative that prevents corrosion during shipment and storage.

This rust preventative has been your machine's close ally and guardian since it left the factory. If your machine arrived to you free of rust, then be thankful that the rust preventative protected it during its journey...and try to stay thankful as you clean it off, because it can be challenging to remove if you are unprepared and impatient.

Plan on spending some time cleaning your machine. The time you spend doing this will reward you with smooth sliding parts and a better appreciation for the proper care of your machine's unpainted surfaces.

Although there are many ways to successfully remove the rust preventative, these instructions walk you through what works well for us.

Before cleaning, gather the following:

- Disposable Rags
- Cleaner/degreaser (see below)
- Safety glasses & disposable gloves

H9692—Orange Power Cleaner & Degreaser

One of the best cleaners we've found for quickly and easily removing rust preventative.



Figure 6. Model H9692 Industrial Orange Power Cleaner/Degreaser (99.9% biodegradable).

Note: *In a pinch, automotive degreasers, mineral spirits or WD•40 can be used to remove rust preventative. Before using these products, though, test them on an inconspicuous area of your paint to make sure they will not damage it.*

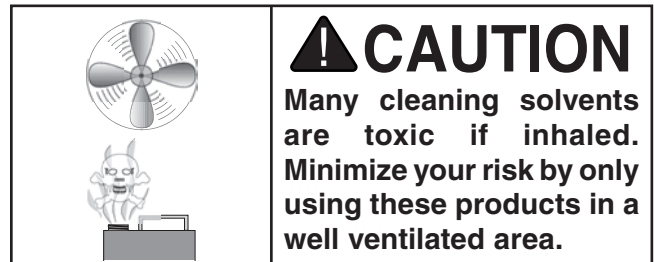
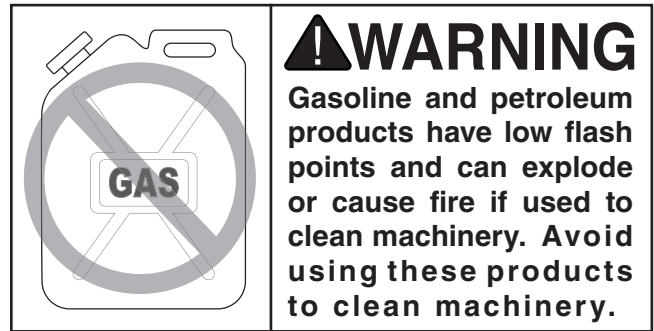

Basic steps for removing rust preventative:

1. Put on safety glasses and disposable gloves.
2. Coat all surfaces that have rust preventative with a liberal amount of your cleaner/degreaser and let them soak for few minutes.

3. Wipe off the surfaces. If your cleaner/degreaser is effective, the rust preventative will wipe off easily.

Note: *To clean off thick coats of rust preventative on flat surfaces, such as tables, use a PLASTIC paint scraper to scrape off the majority of the coating before wiping it off with your rag. (Do not use a metal scraper or you may scratch your machine.)*

4. Repeat **Steps 2–3** as necessary until clean, then coat all unpainted surfaces with a quality metal protectant to prevent rust.



Site Considerations

Weight Load

Refer to the **Machine Data Sheet** for the weight of your machine. Make sure that the surface upon which the machine is placed will bear the weight of the machine, additional equipment that may be installed on the machine, and the heaviest workpiece that will be used. Additionally, consider the weight of the operator and any dynamic loading that may occur when operating the machine.

Space Allocation

Consider the largest size of workpiece that will be processed through this machine and provide enough space around the machine for adequate operator material handling or the installation of auxiliary equipment. With permanent installations, leave enough space around the machine to open or remove doors/covers as required by the maintenance and service described in this manual. **See below for required space allocation.**

	<p>CAUTION Children or untrained people may be seriously injured by this machine. Only install in an access restricted location.</p>
---	---

Physical Environment

The physical environment where your machine is operated is important for safe operation and the longevity of its components. For best results, operate this machine in a dry environment that is free from excessive moisture, hazardous chemicals, airborne abrasives, or extreme conditions. Extreme conditions for this type of machinery are generally those where the ambient temperature range exceeds 41°–104°F; the relative humidity range exceeds 20–95% (non-condensing); or the environment is subject to vibration, shocks, or bumps.

Electrical Installation

Place this machine near an existing power source. Make sure all power cords are protected from traffic, material handling, moisture, chemicals, or other hazards. Make sure to leave access to a means of disconnecting the power source or engaging a lockout/tagout device.

Lighting

Lighting around the machine must be adequate enough that operations can be performed safely. Shadows, glare, or strobe effects that may distract or impede the operator must be eliminated.

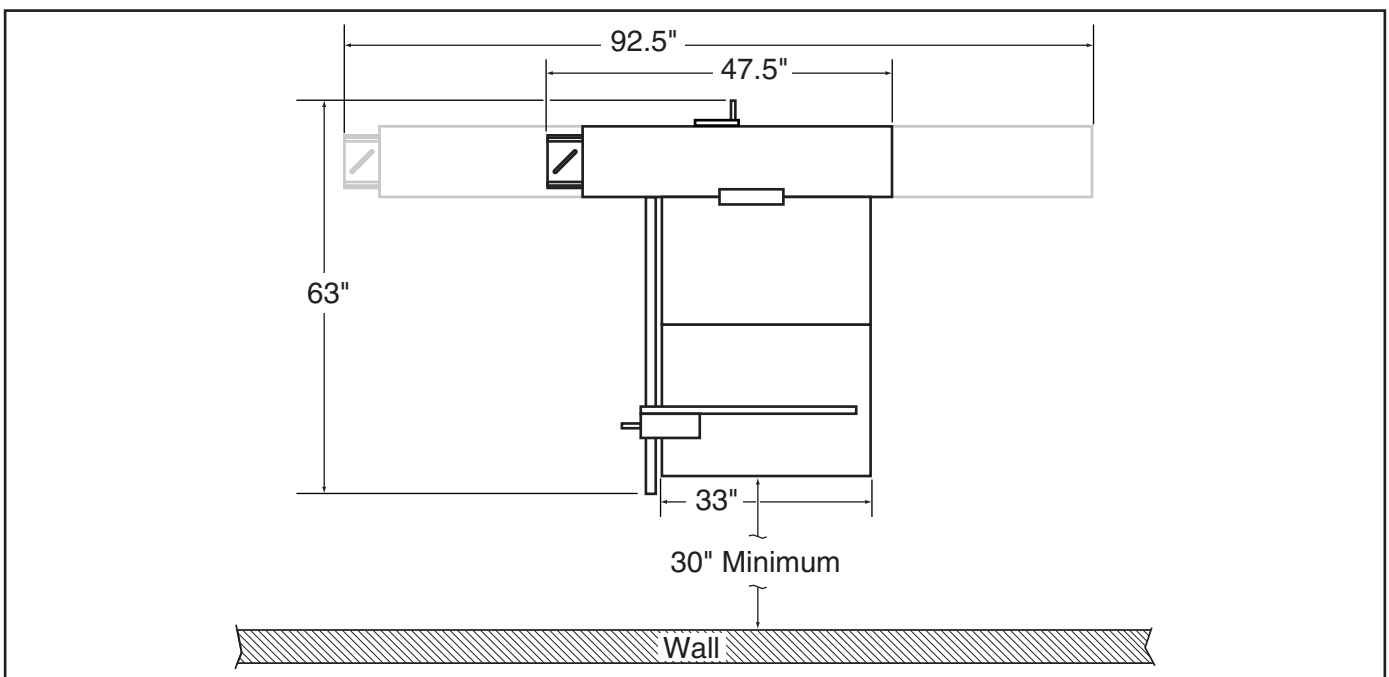

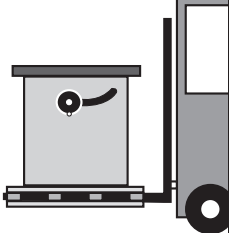

Figure 7. Minimum working clearances.



Moving & Placing Table Saw

	!WARNING This machine and its components are heavy. Serious injury may occur if safe moving methods are not followed.
	Get help when lifting or moving the machine and its components. Use a forklift to reduce the risk of a lifting strain or crushing injury.

If a forklift is not available, a MINIMUM of four strong people are required to move this table saw from the pallet. The table saw can be "walked" off the pallet, then moved into place with a dolly or by sliding it. An additional option would be to put the saw on a Model G7315Z mobile base, so it can be easily moved around the shop (see **Page 56**).

To remove the saw from the pallet:

1. Remove the motor cover
2. Feed the lifting straps around the lifting red bolts on the back of the table and the sliding table saw mounts on the front of the cabinet (see **Figure 8**). Attach the ends of the lifting straps to the forklift forks.



Figure 8. Lifting the table saw with a forklift and lifting straps (sliding table removed for clarity).

3. Lift the table saw cabinet only as high as necessary to clear the pallet, and move it to the desired location.

!WARNING

DO NOT lift the table saw any higher than necessary to clear the floor. Serious personal injury and damage to the machine may occur if safe moving methods are not followed.

4. Remove the red lifting bolts from the back of the table.
5. Place a level on the cast iron table to level the table saw cabinet side to side and front to back. This will allow the table to slide smoothly.

Note: There are three options for leveling the saw: 1) Place it on a mobile base (Grizzly Model G7315Z) and use the mobile base adjustable feet to level it, 2) shim under the cabinet, and 3) thread bolts down into the nuts that are welded on the inside stand corners (see **Figure 9**).

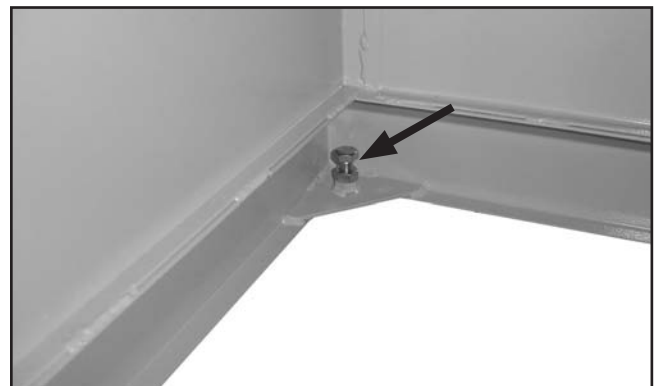

Figure 9. Hex bolt in stand corners for leveling; the hex nut is used to secure the bolt position.



Assembly & Setup

Before shipping, the sliding table was installed on the machine and calibrated to the main table and blade arbor.

The table and fence components are heavy so you must get help lifting and holding them during the installation process.

To assemble the sliding table saw:

1. Attach the extension table to the main table with (3) M10-1.5 x 25 cap screws, 10mm flat washers, and 10mm lock washers (see **Figure 10**). Do not fully tighten the cap screws at this time, because the extension table still needs to be leveled with the main table.

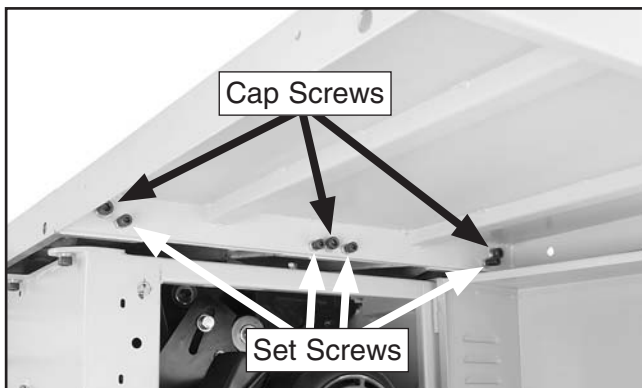

Figure 10. Extension table installed.

2. Thread (1) M8-1.25 hex nut halfway onto each of the (4) M8-1.25 x 25 set screws, then thread the set screws a couple of turns into the locations shown in **Figure 10**. These screws will help you level the table in the next step.
3. Adjust the top of the extension table to be even with the cast iron table and snug the cap screws down enough to hold the table in place.
4. Using a straightedge as a guide (see **Figure 11**), adjust the set screws to align the top of extension table with the top of the main table. When the extension table is fully aligned and leveled with the main table, tighten the hex nuts on the set screws against the extension table to lock them in position.



Figure 11. Extension wing mounted and adjusted evenly with the cast iron table.

5. Mount the rip fence scale to the main table and extension table (see **Figure 12**) with (2) M6-1 x 16 hex bolts, (1) M6-1 x 25 hex bolt, and (3) M6-1 hex nuts, 6mm lock washers, and 6mm flat washers. Do not completely tighten the fasteners at this time, because the rip fence scale will need to be calibrated to the blade during a later step.

Note: The longer hex bolt is used in the cast iron table. Also, make sure the scale is even with both table tops before securing it in place.

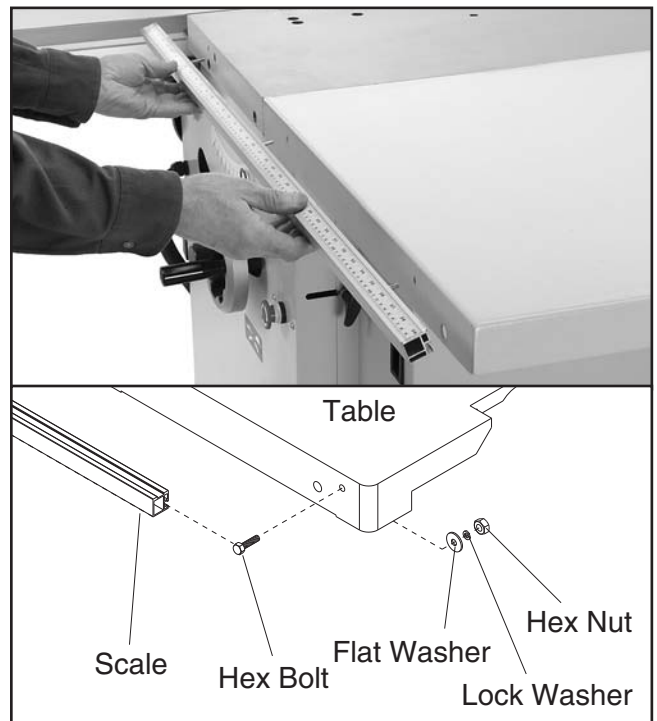

Figure 12. Mounting rip fence scale.



- The fence rail is pre-assembled with four rail studs and accompanying hardware. Remove one hex nut, flat washer, and lock washer from the end of each stud, as shown in **Figure 13**.

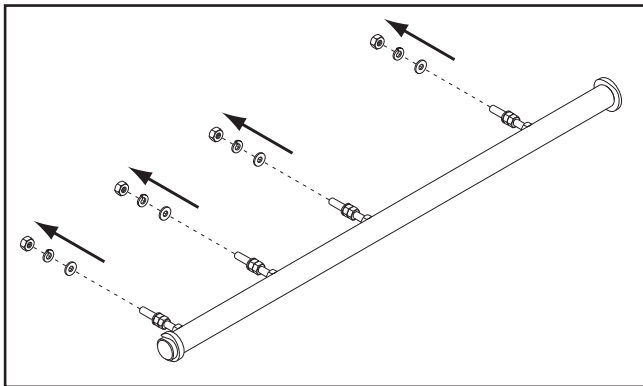

Figure 13. Hardware removed from fence rail studs to prepare for installation.

- Install the rail with the studs through the holes in the tables, as shown in **Figure 14**, and use the hardware removed in the previous step to secure the rail to the tables.

Do not tighten the hex nuts at this time, because the rail still needs to be adjusted.

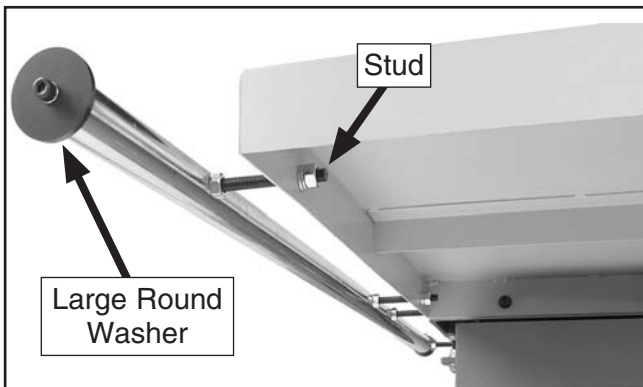

Figure 14. Round rail installed.

- Remove the large round washer attached to the end of the fence rail. With this washer out of the way, you will be able to slide the rip fence base onto the rail.

- Slide the rip fence base onto the round rail. Thread the handles and knob into the rip fence base, where shown in **Figure 15**.

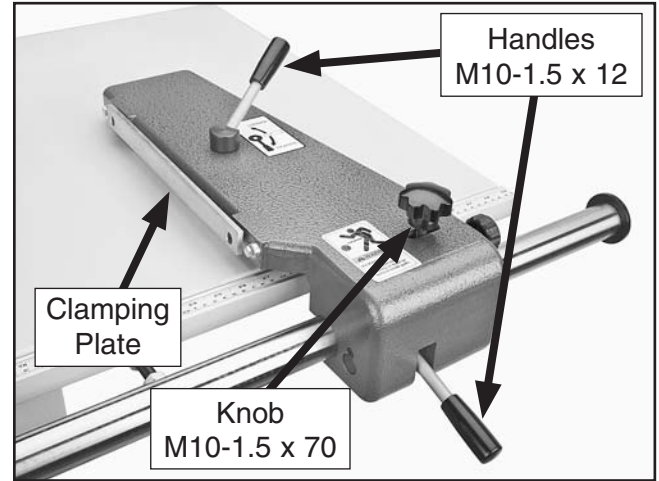

Figure 15. Rip fence handles.

- Slide the rip fence onto the rip fence base by sliding the fence T-slot over the clamping plate (see **Figures 15-16**). Lock the fence by tightening the fence lock handle.

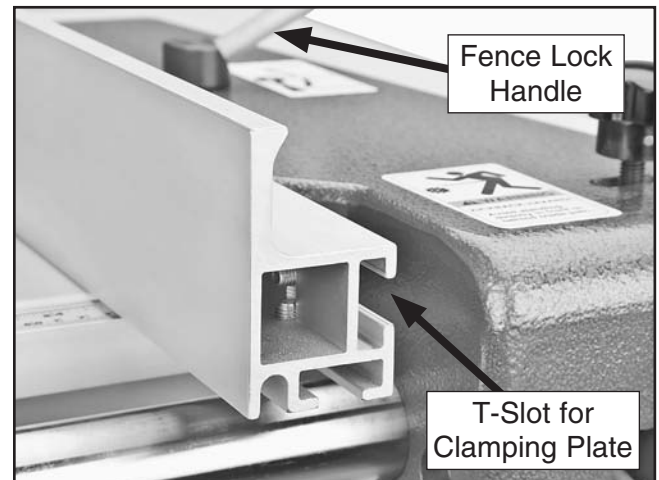

Figure 16. Installing the rip fence.



- Remove the shipping brace from the sliding table, then install the sliding table end cover over the fixed part of the sliding table end, as shown in **Figure 17**, using the premounted hardware. (Save the brace for future transport needs.)

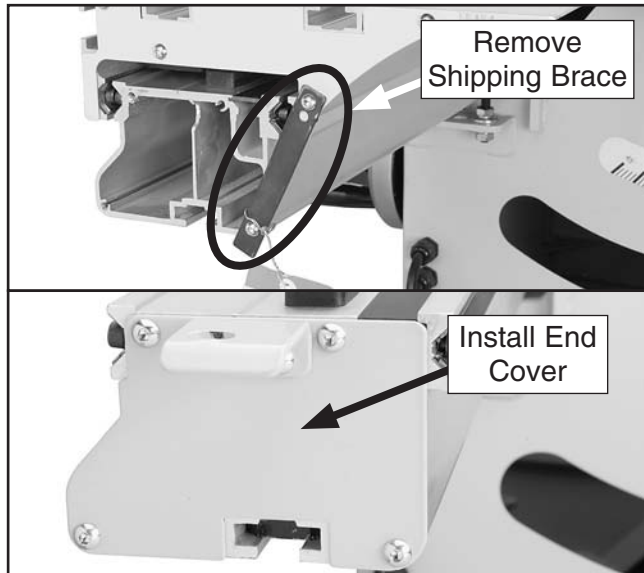

Figure 17. Sliding table shipping brace and end cover installed.

- Attach the push handle assembly, as shown in **Figure 18**, with the two button head screws and flat washers already installed in the mounting holes.

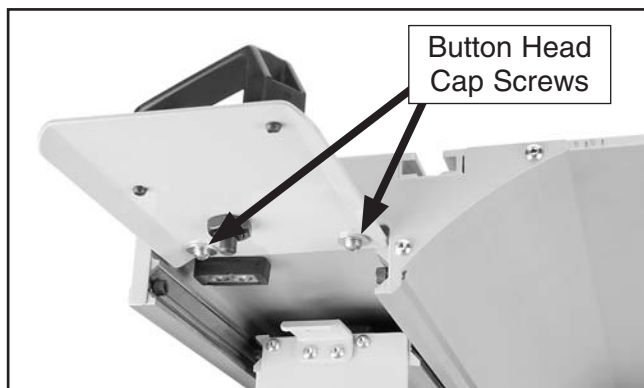

Figure 18. Sliding table handle attached to end of sliding table.

- Thread (2) M5-.8 x 12 cap screws with 5mm lock washers through the switch bracket and into the sliding table base (see **Figure 19**), then tighten the cap screws.



Figure 19. Magnetic switch installed.

- Open the cabinet door and remove the motor shipping brace shown in **Figure 20**, then replace the fasteners where they were. (Save the brace for future transport needs.)

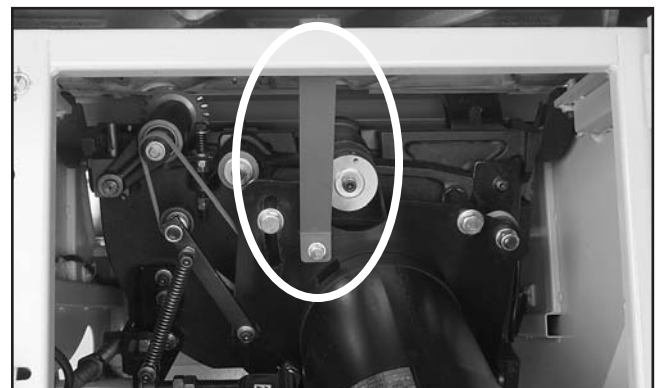

Figure 20. Motor shipping brace.

- Tilt the blade assembly to 0°, then move the sliding table out of the way so you can access the lower blade guard cover and blade arbors.

- Insert the arbor lock tool into the hole shown in **Figure 21**, rotate the arbor until the arbor lock tool seats, then install the main blade per the instructions on **Page 35** as a guide.

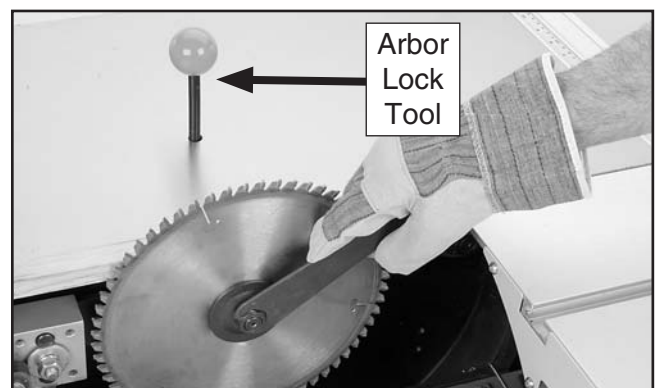

Figure 21. Installing main blade.



17. Install the riving knife (**Figure 22**), using the instructions on **Page 32** as a guide.

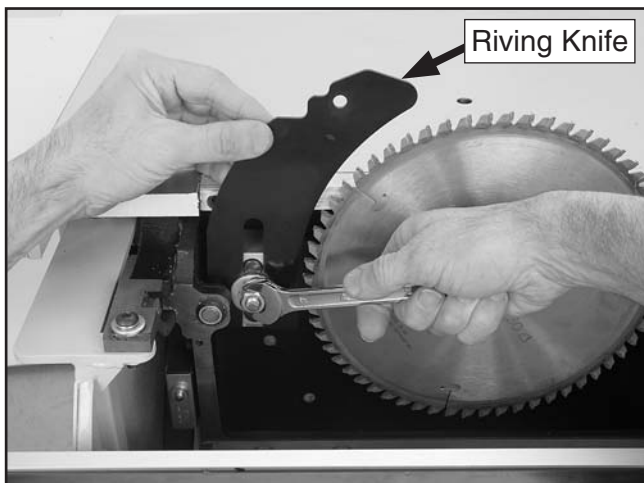

Figure 22. Installing riving knife.

18. Insert the arbor lock tool into the hole shown in **Figure 23**, rotate the arbor until the lock tool seats, then install the scoring blade per the instructions on **Page 36**.

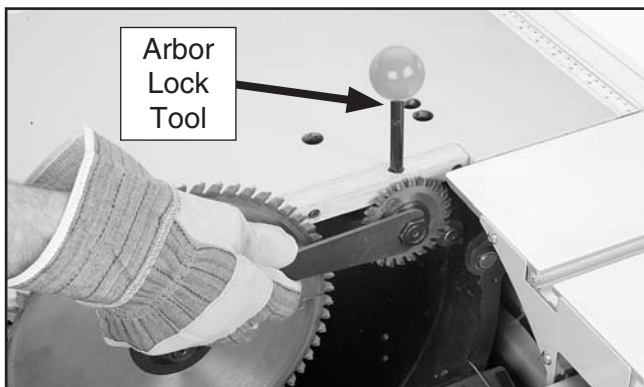

Figure 23. Installing scoring blade.

19. Slide the rip fence over until it just touches the blade.
20. Adjust the mounting position of the round rail until the rip fence evenly touches the entire width of the blade from front to back.

Note: To adjust the mounting position of the round rail, use the hex nuts (on the round rail studs) that are on both sides of the tables.

21. Verify that the metal part of the rip fence does not rest on the surface of the table.

Note: The rip fence body will scratch the table surface if the ride height is not adjusted correctly. Only the roller should touch the table surface.

—If the rip fence body **does not** rest on the table, then the fence is correctly adjusted.

—If the rip fence body **does** rest on the table, carefully remove the rip fence and turn it upside down. Loosen the set screw shown in **Figure 24** and rotate the hex bolt to raise the roller. Tighten the set screw to lock the ride height and recheck how the rip fence rests on the table.

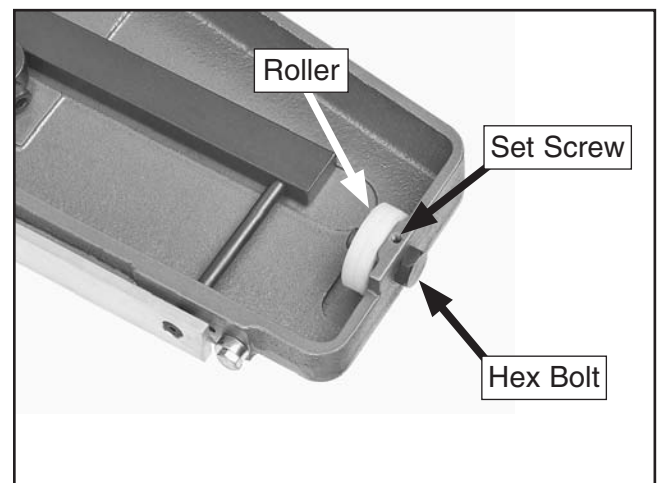

Figure 24. Rip fence height adjustment.

22. Check the height of the rip fence rail by sliding the rip fence along the rail and comparing the gap between the rip fence body and the tables.
23. Adjust the height of the rip fence rail, then tighten all of the hex nuts to secure the round rail in place.
24. Re-install the large round washer on the end of the fence rail to prevent the fence body from sliding off when moved backward.



25. Make sure the fence is just touching the edge of the blade teeth, then adjust the position of the rip fence scale until the edge of the fence is aligned with the 0" mark on the scale. Once it is aligned, carefully tighten the rip fence scale fasteners.
26. Move the fence out of the way, and install the blade guard (Figure 25) per the instructions on Page 31. (This step is mandatory.)

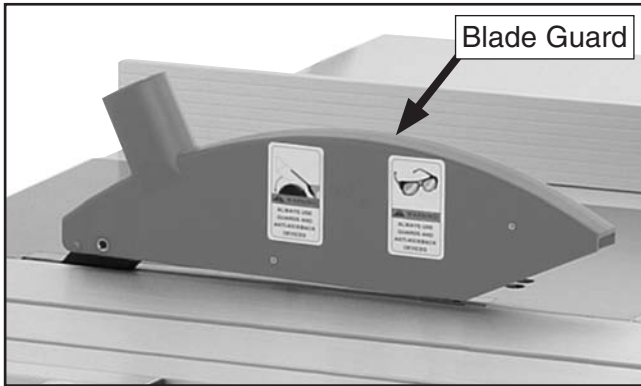

Figure 25. Blade guard installed.

27. Install the miter gauge as shown in Figure 26.

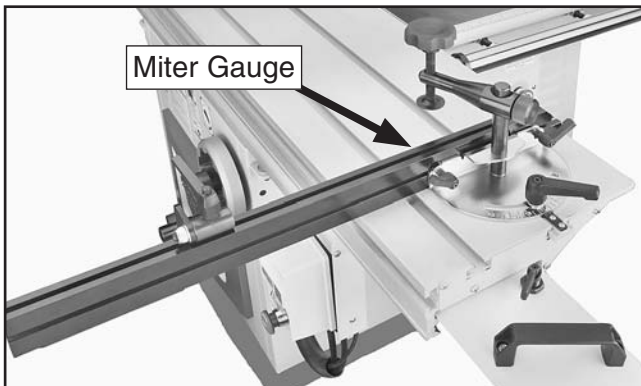

Figure 26. Miter gauge installed.

28. Install the hose support as shown in Figure 27.

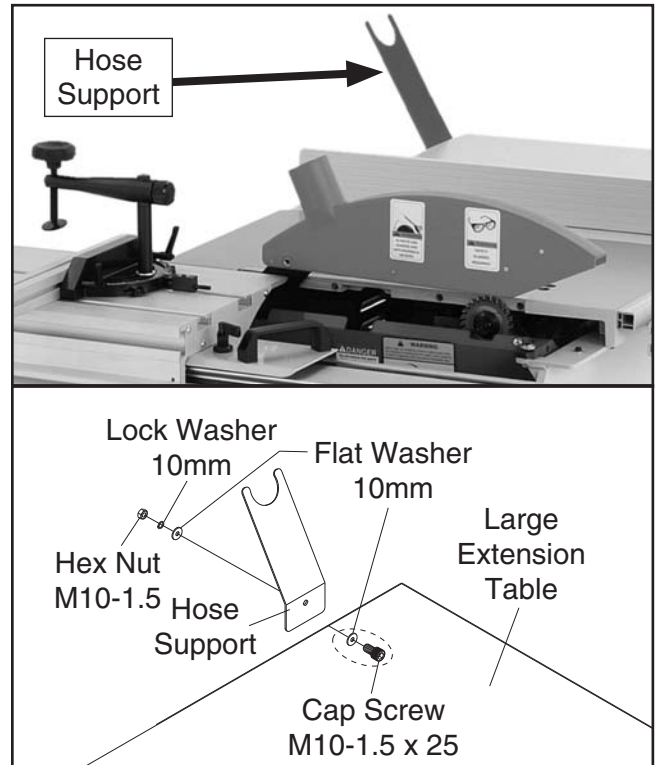

Figure 27. Hose support installed.

⚠ CAUTION

DO NOT operate this saw without an adequate dust collection system. This saw creates substantial amounts of wood dust while operating. Failure to use a dust collection system can result in short and long-term respiratory illness.



NOTICE

Minimum CFM at 4" Dust Port: 400 CFM
Minimum CFM at 2½" Dust Port: 150 CFM

Do not confuse this CFM recommendation with the rating of the dust collector. To determine the CFM at the dust port, you must consider these variables: (1) CFM rating of the dust collector, (2) hose type and length between the dust collector and the machine, (3) number of branches or wyes, and (4) amount of other open lines throughout the system. Explaining how to calculate these variables is beyond the scope of this manual. Consult an expert or purchase a good dust collection "how-to" book.

29. Secure a 4" dust hose to the dust port located under the saw table and the 2½" dust hose to the blade guard (see **Figure 28**).

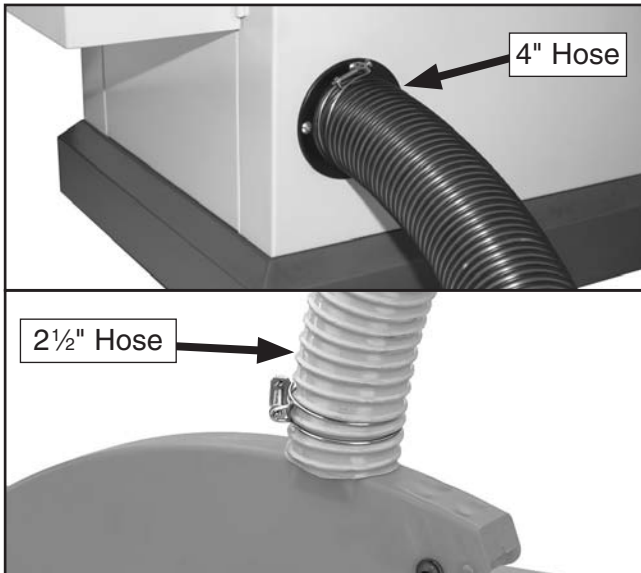

Figure 28. Dust hoses attached.

30. Run the 2½" hose over the hose support, as shown in **Figure 29**.

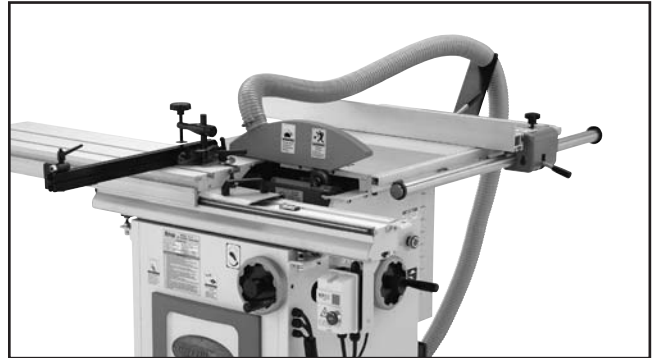

Figure 29. Dust hose support in use.

Tip: The two dust ports can be connected together at the machine with the optional Grizzly accessories shown in **Figure 30**.

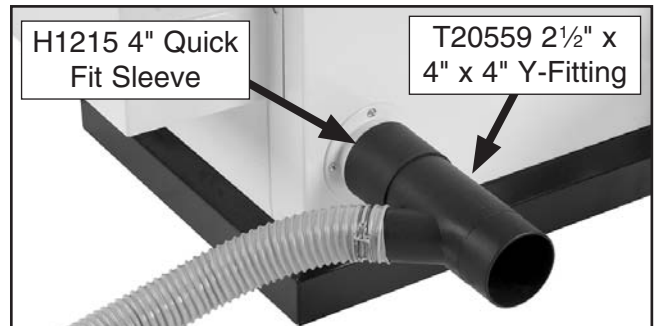

Figure 30. Consolidating dust lines with optional dust collection accessories from Grizzly.

Call 1-800-523-4777 To Order



Power Connection

Before connecting the saw to power, read through **SECTION 2: POWER SUPPLY**, beginning on **Page 12**, to check that your setup follows the safety and circuit requirements for your model.

When installing the power cord, it is **MANDATORY** to make sure the cord is adequately secured to the junction box with a strain relief, so it will not be pulled loose if tripped over or caught on a moving object. The strain relief firmly attaches to the junction box and clamps against the cord when tightened. Also, it is important to firmly tighten terminal screws, so wires cannot come loose from any operational vibrations that may occur over time.

If the cord or wires are pulled loose, the wires can cause a short, which may lead to fire, shock, or machine damage.

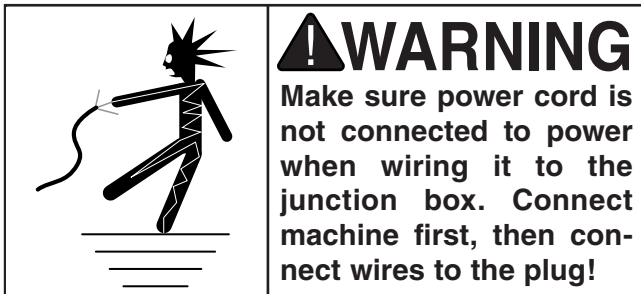

To connect the saw to the power supply:

1. Open the junction box shown in **Figure 31**.

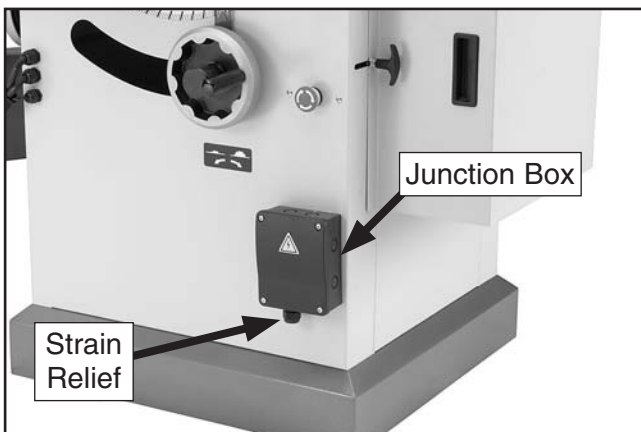

Figure 31. Location of junction box and strain relief.

2. Loosen the strain relief and slide the power cord through it and into the junction box.

3. Attach the hot wires to the terminals across from the wires marked "S" and "R" (see **Figure 32**), and attach the ground wire to the terminal across from the green wire tagged with the ground symbol. Make sure the terminal screws are firmly tightened so the wires will not pull out.

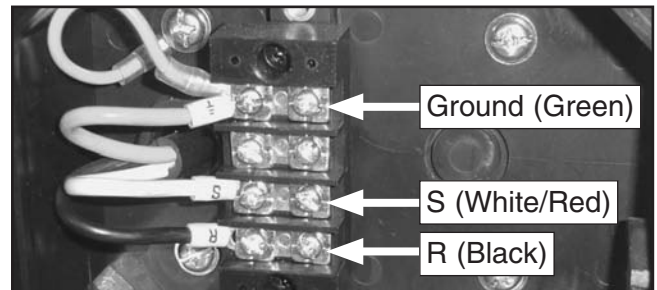

Figure 32. Location to connect incoming power supply wires inside junction box.

4. Make sure the wires have adequate slack between the strain relief and the terminals, then tighten the strain relief against the power cord jacket—not the wires.
5. Test the strain relief by pulling on the cord from outside the box, using moderate force. When properly secured, the cord will remain in place and not slide in the strain relief.
6. Replace the power box cover.
7. Connect the required plug to the other end of the power cord, using the wiring instructions provided by the plug manufacturer.

If the wiring instructions are not provided with the plug, refer to the wiring diagram in this manual. The plug wiring shown in the diagram is drawn from NEMA standards for the plug type shown. If your plug does not match the one shown in the wiring diagram in this manual, please contact technical support before proceeding any further.

8. Clear away any tools used during the assembly process, and press the STOP button on the magnetic switch to ensure that the ON button is not engaged.
9. Plug the machine into the power source and proceed to the following **Test Run** section to verify that the saw operates correctly and is ready for cutting operations.



Test Run

The purpose of the test run is to verify that the newly assembled machine runs properly and all safety devices are in proper working condition before any cutting operations are performed.

It is extremely important that all previous assembly and setup sections have been performed before performing this procedure. Also, it is **MANDATORY** that all steps in this section be followed very carefully and in the order given to ensure that the machine is correctly tested.

Before beginning the test run, review the power controls shown in **Figures 33–34** and the controls and components shown in **Identification** on **Page 3**.

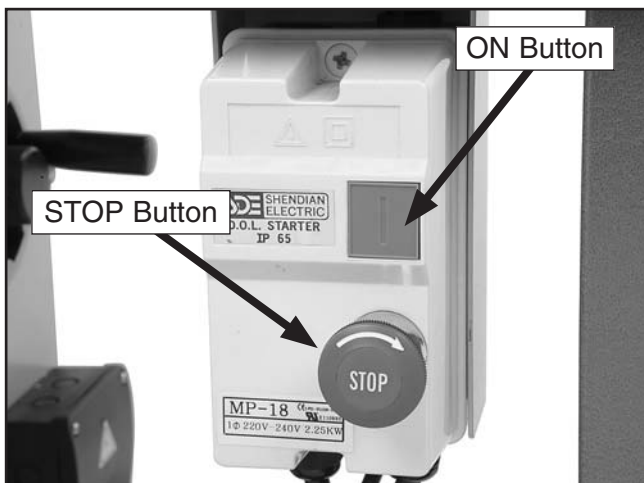

Figure 33. Main power switch.



Figure 34. Emergency STOP button.

!WARNING

If the machine does not operate as stated in this section, review the troubleshooting section on Page 60. If you need additional help, call Tech Support at (570) 546-9663. **DO NOT** place a machine into regular operation if you suspect that it is malfunctioning, or serious injury could occur.

To test run the saw:

1. Put on safety glasses, make sure any bystanders are out of the way, and that all tools have been removed from the saw.
2. Push in, then rotate the power switch STOP button clockwise until it pops out. Do the same thing on the emergency STOP button. This resets the switches so the saw can be started.
3. Press the ON button. The blades should start and run smoothly without any problems. *If any problems occur, immediately press either STOP button, then troubleshoot and correct the before starting the saw again.*
4. Make sure the power switch STOP button is pushed in all the way and the emergency STOP button is reset (popped out), then press the ON button.

—The saw should NOT start when either of the STOP buttons are pushed in. If this is true, repeat this test with the emergency STOP button pushed in and the power switch stop button reset.

—If the saw DOES start when either STOP button is pushed in, then it is not functioning correctly. Call Tech Support for advice before proceeding any further with the test run or machine operations.
5. If you successfully completed **Steps 1–4** above, congratulations! The table saw is now ready for cutting operations.



SECTION 4: OPERATIONS

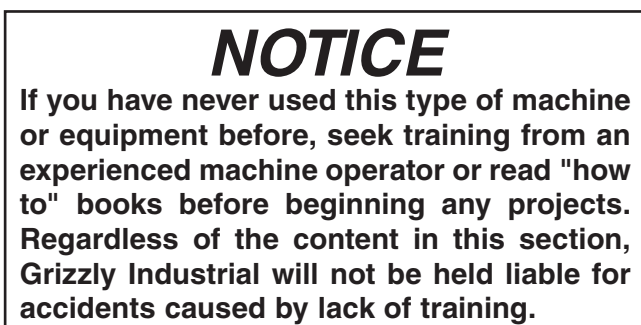
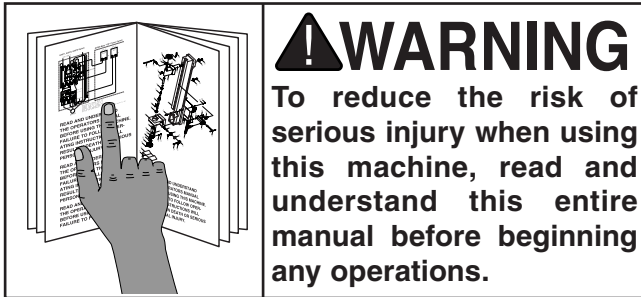

Operation Overview

The purpose of this overview is to provide the novice machine operator with a basic understanding of how the machine is used during a typical operation, so the controls/components discussed later in this manual are easier to understand.

Due to the generic nature of this overview, it is not intended to be an instructional guide. To learn more about specific operations, read this entire manual, read "how to" books, and seek additional training from experienced machine operators.

To complete a typical operation, the operator does the following:

- Examines the workpiece to make sure it is suitable for cutting.
- Adjusts the blade tilt, if necessary, to the correct angle of the desired cut.
- Adjusts the blade height approximately $\frac{1}{4}$ " higher than the thickness of the workpiece.
- Adjusts the fence to the desired width of cut then locks it in place.
- Checks the outfeed side of the machine for proper support and to make sure the workpiece can safely pass all the way through the blade without interference.
- Puts on safety glasses and a respirator, and locates push sticks if needed.
- Starts the saw.
- Feeds the workpiece all the way through the blade while maintaining firm pressure on the workpiece against the table and fence, and keeping hands and fingers out of the blade path and away from the blade.
- Stops the machine immediately after the cut is complete.



Workpiece Inspection

Some workpieces are not safe to cut on this machine or may need to be modified before they can be safely cut. **Before cutting, inspect all workpieces for the following:**

- **Material Type:** This machine is intended for cutting natural and man-made wood products, laminate covered wood products, and some plastics. Cutting drywall or cementitious backer board creates extremely fine dust and may reduce the life of the motor bearings. This machine is NOT designed to cut metal, glass, stone, tile, etc.; cutting these materials with a table saw greatly increases the risk of injury and damage to the saw or blade.
- **Foreign Objects:** Nails, staples, dirt, rocks and other foreign objects are often embedded in wood. While cutting, these objects can become dislodged and hit the operator, cause kickback, or break the blade, which might then fly apart. Always visually inspect your workpiece for these items. If they can't be removed, DO NOT cut the workpiece.
- **Large/Loose Knots:** Loose knots can become dislodged during the cutting operation. Large knots can cause kickback and machine damage. Choose workpieces that do not have large/loose knots or plan ahead to avoid cutting through them.
- **Wet or "Green" Stock:** Cutting wood with a moisture content over 20% causes unnecessary wear on the blades, increases the risk of kickback, and yields poor results.
- **Excessive Warping:** Workpieces with excessive cupping, bowing, or twisting are dangerous to cut because they are unstable and may move unpredictably when being cut.
- **Minor Warping:** Slightly cupped workpieces can be safely supported with cupped side facing the table or fence; however, workpieces supported on the bowed side will rock during the cut, which could cause kickback.

Non-Through & Through Cuts

Non-Through Cuts

A non-through cut is a sawing operation where the blade does not protrude above the top face of the wood stock, as shown in the **Figure** below.

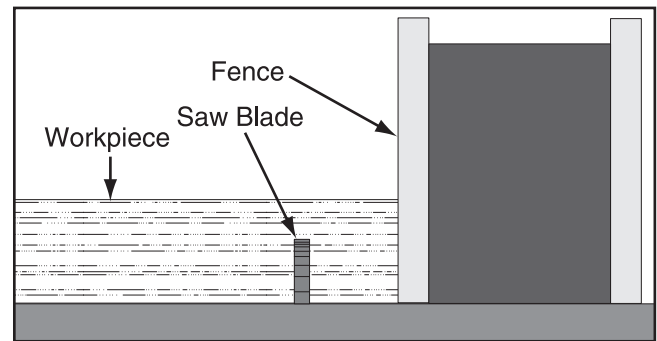

Figure 35. Example of a non-through cut.

Examples of non-through cuts include dados and rabbets. Non-through cuts have a higher risk of injury from kickback because the blade guard must be removed. However, the riving knife **MUST** be installed because it still provides some protection. When making non-through cuts with a dado blade, do not attempt to cut the full depth in one pass. Instead, take multiple light passes to reduce the load on the blade. A dado blade smaller than 10" will require removal of the riving knife, because the riving knife will be higher than the blade.

Through Cuts

A through cut is a sawing operation in which the workpiece is completely sawn through, as shown in the **Figure** below. Examples of through cuts are rip cuts, cross cuts, miter cuts, and beveled cuts. The blade guard assembly **MUST** be used when performing through cuts.

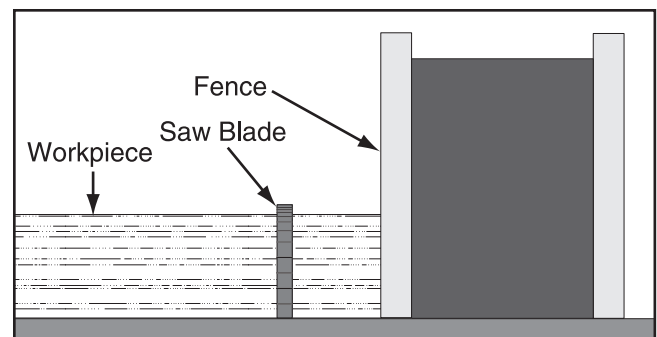

Figure 36. Example of a through cut (blade guard not shown for illustrative clarity).



Blade Guard & Riving Knife

The term "blade guard" refers to the assembly that consists of the guard and riving knife assembly (see **Figure** below). Each of these components have important safety functions.

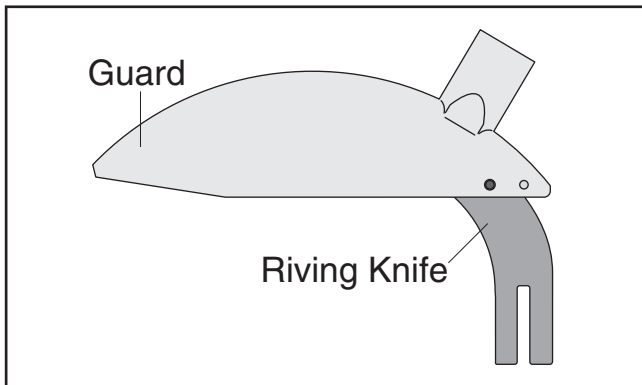

Figure 37. Blade guard assembly components.

Understanding the Blade Guard

The guard encloses the top of the blade to reduce the risk of accidental blade contact and contain flying chips or dust.

The guard is designed to lift as the workpiece is pushed into the blade, remain in contact with the workpiece during the cut, then return to a resting position against the table when the cut is complete. When installed and properly maintained, the guard is an excellent tool for reducing the risk of injury when operating the table saw.

To ensure that the guard does its job effectively, it **MUST** be installed and adjusted so that it moves up and down properly to accommodate workpieces and maintain coverage over the blade.

Understanding the Riving Knife

The riving knife is a metal plate that prevents the freshly cut pieces of the workpiece from pinching the backside of the blade and causing a kickback. It also acts as a barrier behind the blade to shield hands from being pulled into the blade if a kickback occurs and the operator is reaching behind the blade. (Reaching behind the blade is a major safety risk and should not be done).

!WARNING

To ensure that the riving knife works safely, it **MUST** be aligned with and correctly adjusted to the blade.

When to Use the Blade Guard

The blade guard **MUST** be installed on the saw for all normal through cuts (defined on **Page 30**).

Sometimes the blade guard or its components can get in the way when cutting very narrow workpieces or other specialized cuts. Because the blade guard is provided to decrease your risk of injury, it should not be used if it gets in the way of making a safe cut. Use good judgment!

In general, the blade guard **MUST** remain installed on the saw—unless a specific operation requires its removal. If the blade guard is removed for specific operations, always immediately replace it after those operations are complete.

When to Use the Riving Knife Only

Use the riving knife without the blade guard for any non-through cuts (defined on **Page 30**) or narrow/specialized cuts in which the blade guard gets in the way of a safe cut.

Always immediately replace the blade guard when these cuts are complete!

When Not to Use Riving Knife

If you use a dado blade that has a diameter smaller than 10", the riving knife will be taller than the top of the blade, which will prevent the cut from being completed. In this case, the only way to complete the cut is to remove the riving knife.



Riving Knife Installation & Removal

The riving knife must be correctly installed, adjusted, and aligned in order to provide the maximum safety benefit.

The riving knife attaches to the mounting block as shown in **Figure 38**. Always firmly tighten the hex nut when securing the riving knife in place.

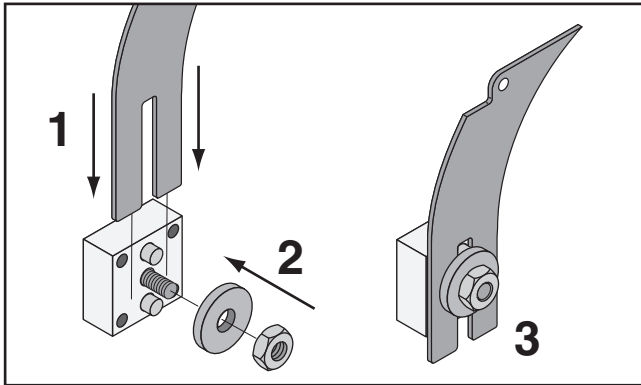

Figure 38. Installing riving knife on mounting block.

Secure the riving knife so that the top of it is 1–5mm below the top level of the blade, as shown in **Figure 39**.

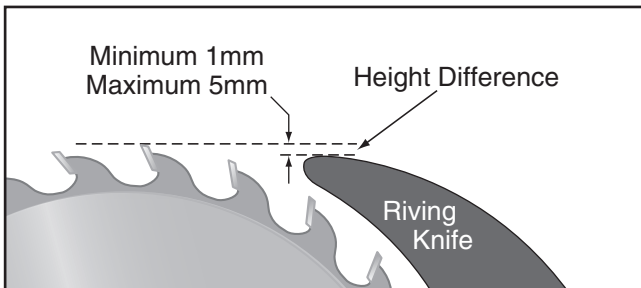

Figure 39. Height difference between riving knife and blade.

The height difference between the riving knife and the blade allows the workpiece to pass over the blade during non-through cuts (those in which the blade does not cut all the way through the thickness of the workpiece).

The riving knife also prevents the freshly cut sides of the workpiece from pinching the blade and causing kickback. For maximum effectiveness of this safety design, the riving knife must be positioned within 3–8mm from the blade, as shown in **Figure 40**.

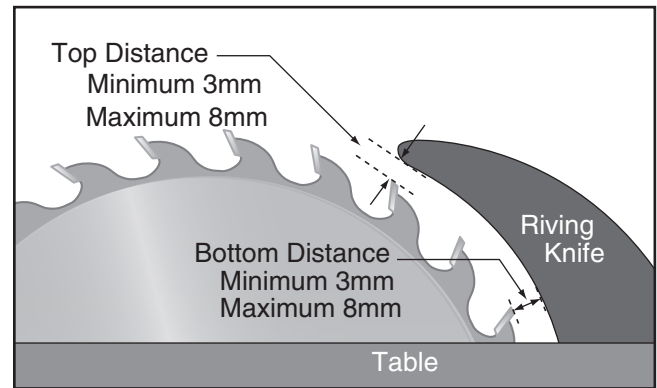

Figure 40. Allowable top and bottom distances between riving knife and blade.

Once the riving knife is properly positioned at the correct distance from the blade, verify that it is aligned with the blade by checking the alignment with a straightedge in the top and bottom locations shown in **Figure 41**.

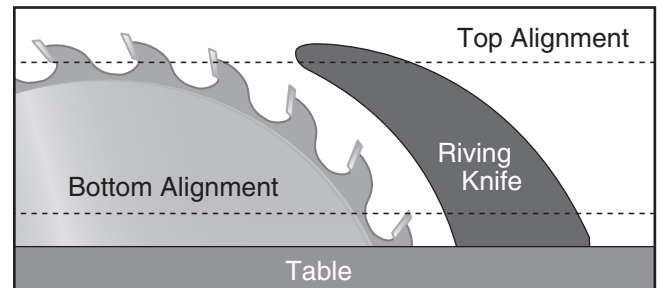

Figure 41. Checking top and bottom riving knife alignment with blade.

The riving knife should be parallel with the blade along its length at both positions and should be in the "Alignment Zone" shown in **Figure 42**.

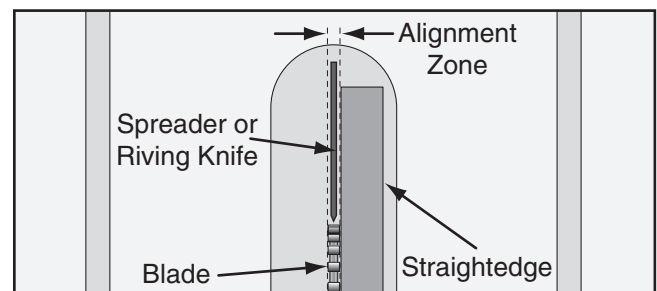

Figure 42. Verifying that riving knife is in the alignment zone behind the blade.

If the riving knife is not aligned or parallel with the blade, refer to **Adjusting Riving Knife Mounting Block** on **Page 66**.



Blade Guard Installation & Removal

The blade guard fits over the riving knife and is secured in place with one M8-1.25 x 40 button head cap screw (see "Mounting Screw" in **Figure 43**). This is the only fastener that needs to be installed/removed when installing or removing the blade guard.

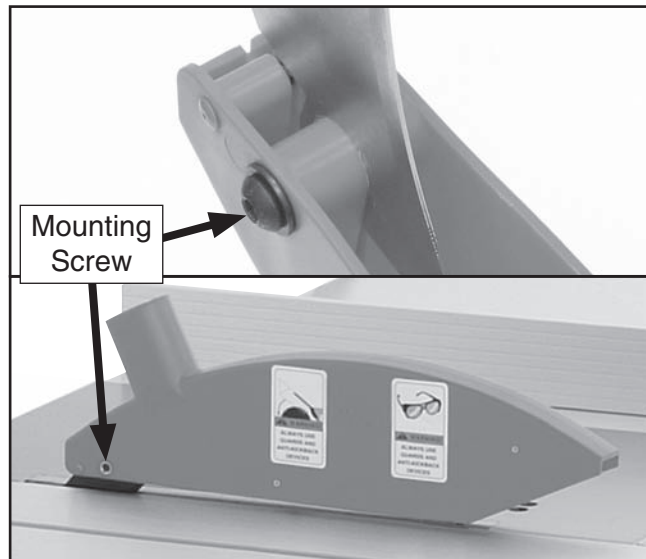

Figure 43. Blade guard mounted to riving knife.

When installing the blade guard, the mounting screw must be left loose enough that the guard can freely pivot up and down, but not so loose that there is side-to-side play when pivoting.

Testing Guard for Correct Operation

After installing the blade guard, you must verify that it functions correctly before making a cut. To test the blade guard operation, lift up the front end about 4" then release it.

- If the blade guard freely drops down against the table surface, then it is functioning correctly and is ready for operation.
- If the blade guard remains in the position where you released it, or it does not drop down against the surface of the table, then the mounting screw is too tight. Loosen it slightly and repeat this test until the guard functions correctly.
- If the blade guard feels loose and easily moves back and forth as you raise it, then the mounting screw is too loose. Tighten it slightly and repeat this test until the guard functions correctly.



Blade Requirements

The riving knife included with this machine is 0.090" (2.3mm) thick and is only designed for 10" diameter blades.

When choosing a main blade, make sure the blade size meets the requirements listed below. The thickness of the blade body and teeth can be measured with calipers or any precision measuring device.

Blade Size Requirements:

- Body Thickness: 0.079"–0.090" (2.0mm–2.3mm)
- Kerf (Tooth) Thickness: 0.122"–0.129" (3.1mm–3.3mm)

Blade Selection

This section on blade selection is by no means comprehensive. Always follow the saw blade manufacturer's recommendations to ensure safe and efficient operation of your table saw.

Ripping Blade Features:

- Best for cutting with the grain
- 20-40 teeth
- Flat-top ground tooth profile
- Large gullets for large chip removal

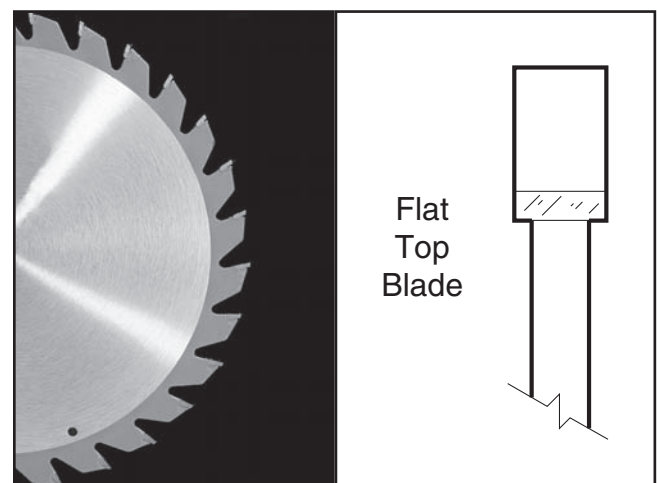

Figure 44. Ripping blade.

Crosscut blade features:

- Best for cutting across the grain
- 60-80 teeth
- Alternate top bevel tooth profile
- Small hook angle and a shallow gullet

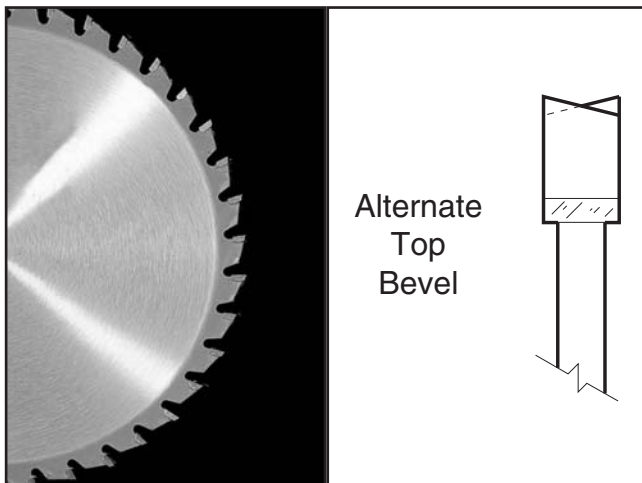

Figure 45. Crosscutting blade.

Laminate blade features:

- Best for cutting plywood or veneer
- 40-80 teeth
- Triple chip tooth profile
- Very shallow gullet

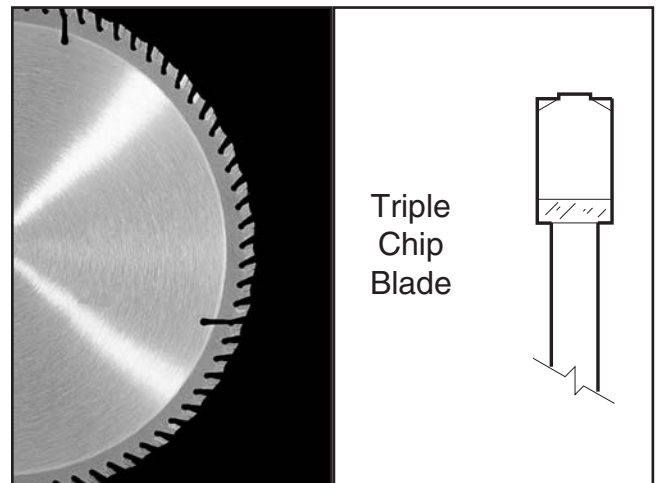

Figure 47. Laminate blade.

Combination blade features:

- Designed to cut both with and across grain
- 40-50 teeth
- Alternate top bevel and flat, or alternate top bevel and raker tooth profile
- Teeth are arranged in groups
- Gullets are small and shallow (similar to a cross-cut blade), then large and deep (similar to a ripping blade)

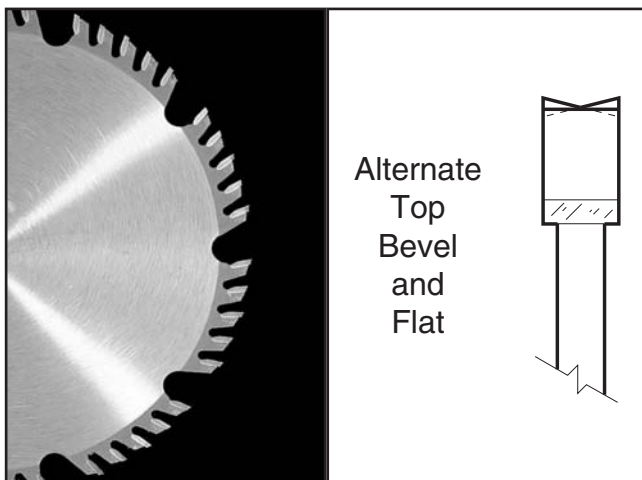

Figure 46. Combination blade.

Thin Kerf Blade: A blade with thinner kerf than a standard blade. Since the spreader/riving knife included with this table saw is sized for standard blades, thin kerf blades cannot be used on this saw unless they meet the **Blade Requirements** specified in this manual; otherwise, they will increase the risk of kickback.

Dado Blades

Stacked Dado Blade (see below): Multiple blades are stacked together to control the cutting width. Stacked dado blades are more expensive than wobble blades, but typically produce higher quality results.

Wobble Dado Blade: A single blade mounted at a slight angle on an arbor hub. The blade angle is adjustable on the hub, and the width of the dado cut is controlled by the angle setting of the blade.

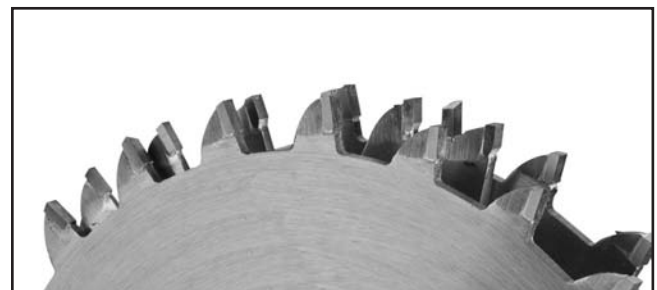

Figure 48. Stacked dado blade.



Changing Main Blade

This saw performs best with high-quality sharp blades. Whenever the blades become dull, replace or have them sharpened.

To change the main blade:

1. DISCONNECT SAW FROM POWER!
2. Move the blade tilt to 0° (blade 90° to table) and raise the main blade as far as it will go.
3. Move the sliding table out of the way to expose the lower blade cover that covers the blades and riving knife, as shown in **Figure 49**.

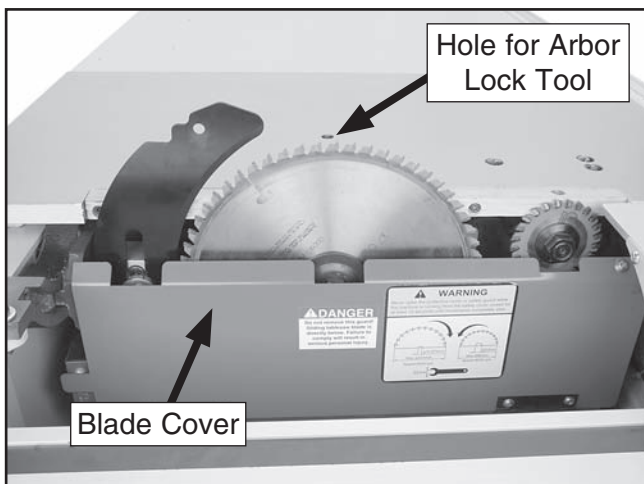

Figure 49. Blade cover made accessible with sliding table moved out of the way.

4. Pull the blade cover away from the blades to expose the mounting assembly. (The blade cover is held closed with a magnet.)
5. Insert the arbor lock tool into the hole shown in **Figure 49**, then rotate the blade by hand until the arbor lock tool seats.

CAUTION

Before proceeding with the next step, wear gloves to protect your hands while handling and installing the blade.

6. Use the arbor wrenches to remove the arbor nut and arbor flange, as shown in **Figure 50**, then pull the old blade off the arbor. *The arbor nut has left-hand threads and loosens by turning clockwise.*

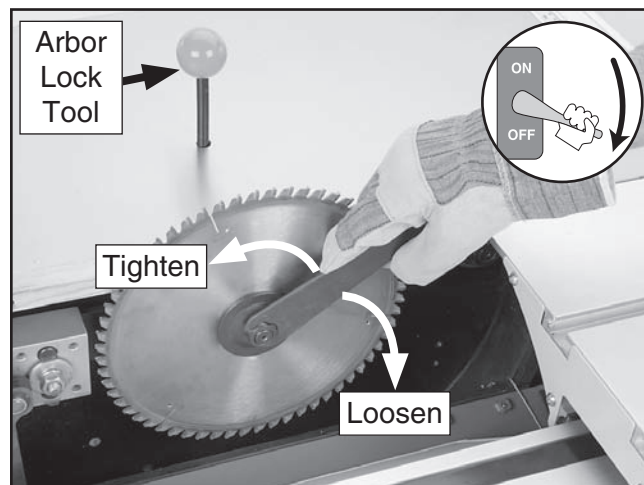

Figure 50. Replacing the main blade.

7. Install the blade as shown in **Figure 51**, making sure the teeth face toward the scoring blade. DO NOT overtighten the arbor nut.

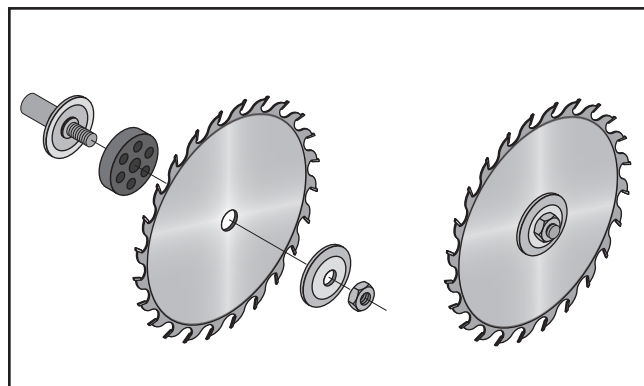

Figure 51. Main blade installation and order of assembly.

— If you changed the diameter of the blade during this procedure, adjust the riving knife according to **Riving Knife Installation & Removal** on **Page 32**.

8. Move the blade cover back into its original position next to the blades, then center the sliding table.



Changing/Adjusting Scoring Blade

The scoring blade included with the Model G0700 has wedge shaped teeth. With this style of scoring blade, the kerf thickness is adjusted by changing the height of the scoring blade. Raising the scoring blade higher increases the kerf thickness.

Changing Scoring Blade

1. DISCONNECT SAW FROM POWER!
2. Remove the blade guard and move the blade tilt to 0° (blade 90° to table).
3. Move the sliding table to the side and pull the blade cover open.
4. Insert the arbor lock tool in the table, rotate the scoring blade to seat the arbor lock tool, and use the arbor wrenches to remove the arbor nut and scoring blade (see **Figure 52**).

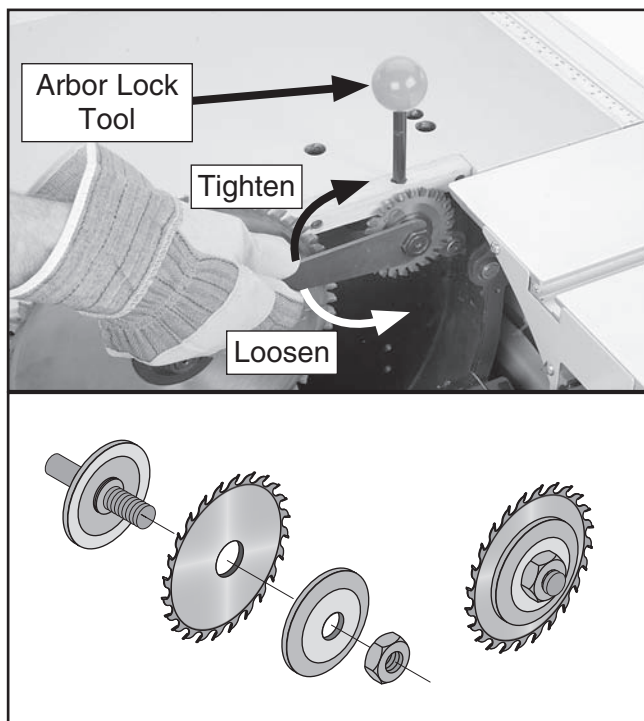

Figure 52. Removing/installing scoring blade.

5. Install the new scoring blade as shown in **Figure 52**, tighten the arbor nut, and adjust the scoring blade alignment and height as necessary.

Adjusting Scoring Blade

1. DISCONNECT SAW FROM POWER!
2. Unlock the scoring blade controls by inserting a 6mm hex wrench into the controls lock hole shown in **Figure 53** and turning the mechanism inside counterclockwise until loose.

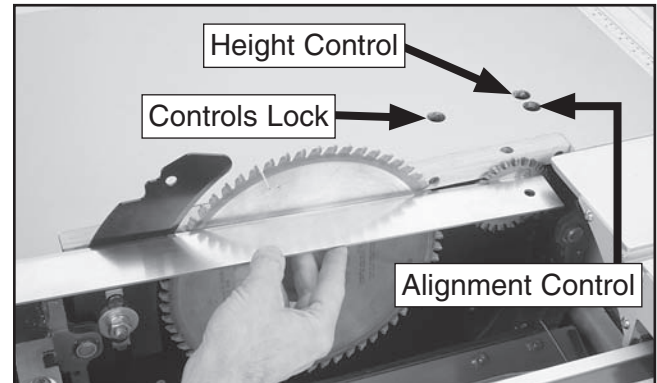

Figure 53. Checking and adjusting scoring blade positioning.

3. Place a straightedge across the body of the main blade (not the teeth) and align the body of the scoring blade to the main blade, by turning the alignment control (**Figure 53**) with a 6mm hex wrench.
4. Adjust the height of the scoring blade, by turning the height control (**Figure 53**) with a 6mm hex wrench, until the exposed portion equals the kerf thickness of the main blade.

Note: The easiest way to match the scoring blade kerf is by laying a straightedge on the table, and placing it up against the main blade teeth and beyond the scoring blade, then adjusting the scoring blade height until its teeth align with the main blade teeth. Also check on the other side of the blades to verify that the kerf thickness matches and the scoring blade is aligned with the main blade.

5. Tighten the controls lock.
6. Move the blade cover back into its original position next to the blades, then center the sliding table.
7. Perform a test cut and check for chip out on the underside of the test piece. If there is chip out, make the adjustments necessary to match the kerfs.



Rip Cutting

This saw has the capability of rip cutting large panels, as shown in **Figure 54**. The sliding table removes the burden of sliding a large and heavy panel over a stationary table surface.

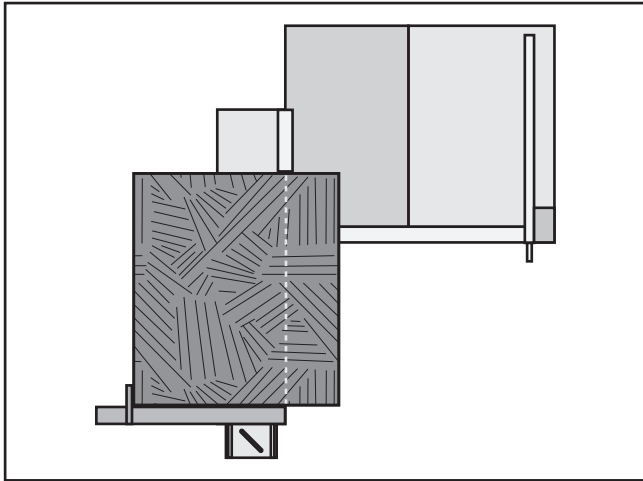

Figure 54. Rip cutting with the sliding table.

This saw also has the capability of rip cutting in the same manner as a traditional table saw, as shown **Figure 55**.

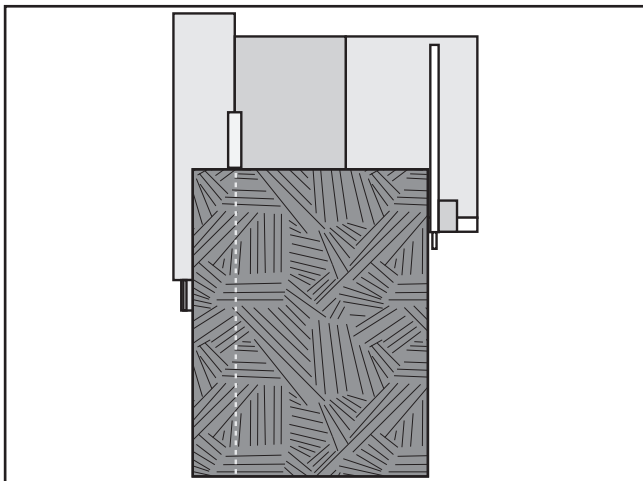

Figure 55. Traditional rip cutting.

Rip Cutting with Sliding Table

1. Install the miter fence on the sliding table, as shown in **Figure 56**.



Figure 56. Miter fence mounting locations.

2. Adjust the fence angle to 0° , using the angle scale on the miter gauge. If the cut requires extreme precision, adjust the miter fence as described in **Squaring Miter Fence to Blade** on **Page 65**.
3. Adjust the miter fence so it does not extend into the cutting path of the blade.
4. Set the flip stop to the desired width-of-cut.
5. Load the workpiece onto the table saw. The set up should look similar to **Figure 54**.
6. Adjust the height of the main blade approximately $\frac{1}{8}$ "– $\frac{1}{4}$ " above the top of the workpiece.
7. Take all the necessary safety precautions, then perform the cutting operation.



Rip Cutting with Rip Fence

1. Lock the sliding table in a stationary position in front of the saw. (The table will only lock in place when it is centered in front of the saw and the sliding table lock is in the locked position (see **Figure 57**).

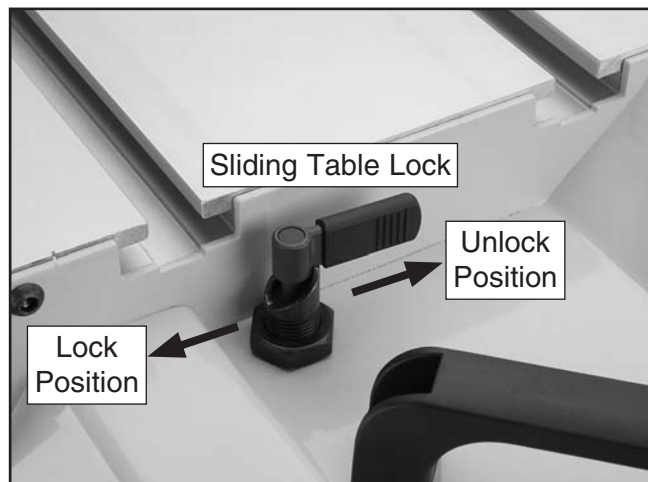

Figure 57. Sliding table lock.

2. Place the fence in the vertical position for larger workpieces, or in the horizontal position for angled cuts and for small workpieces (see **Figure 58**).

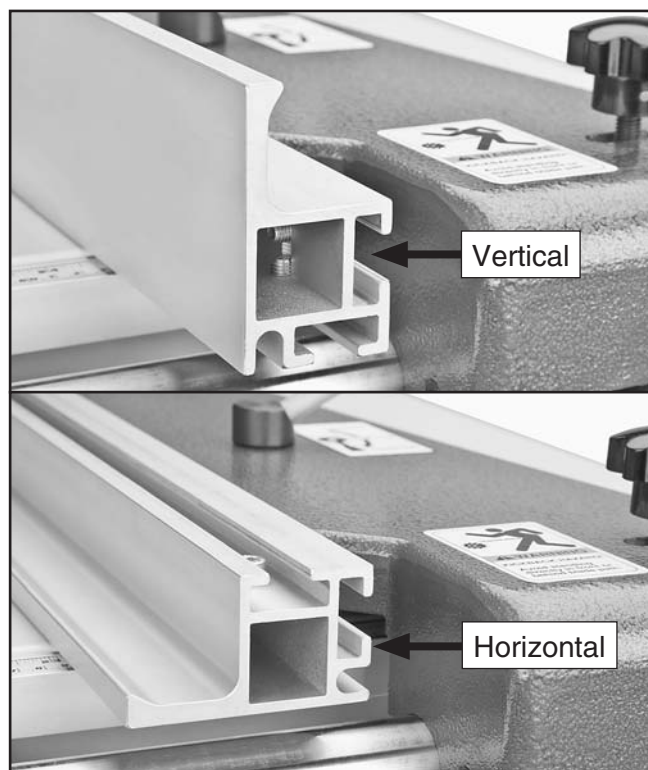

Figure 58. Rip fence positions.

3. Adjust the rip fence to the location necessary for the width of cut, lining up the edge of the rip fence where necessary on the scale (see **Figure 59**), then locking the fence in place.

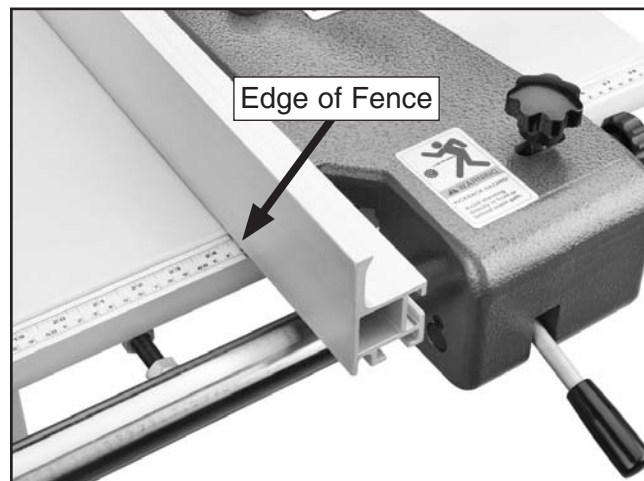

Figure 59. Edge of rip fence over scale indicates cutting width.

4. Load the workpiece onto the table saw. The set up should look similar to **Figure 55**.
5. Adjust the height of the main blade approximately $\frac{1}{8}$ "– $\frac{1}{4}$ " above the top of the workpiece.
6. Take all the necessary safety precautions, then perform the cutting operation as you would with a traditional table saw (by sliding the workpiece firmly along the fence until the cut is complete).



Crosscutting

The Model G0700 can crosscut with the fence in the forward or rear position, although it is easier to load large workpieces with the miter fence mounted in the forward position (see **Figure 60**).

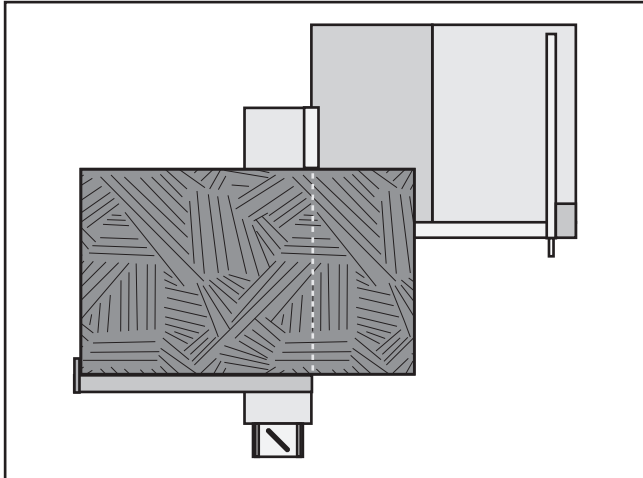

Figure 60. Crosscutting with miter fence in the forward position.

Mounting the miter fence in the rear position (see **Figure 61**) gives greater stability for crosscutting smaller panels.

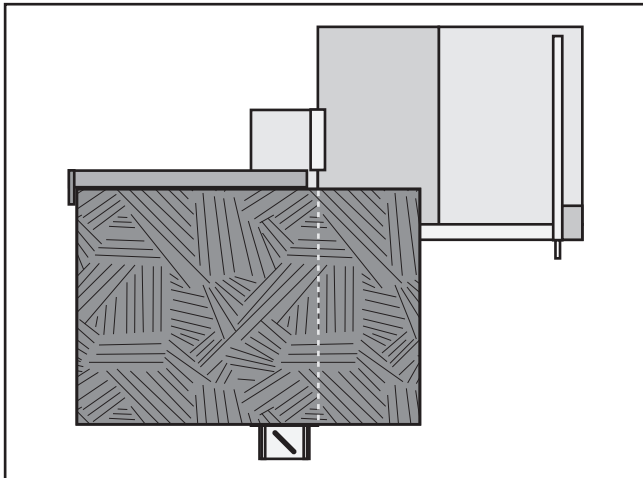

Figure 61. Crosscutting with miter fence in the rear position.

Also, if setup correctly the rip fence can be used as a stop block for making repeat cuts of the same width. **Figure 62** shows the proper fence position in relation to the blade when using the fence as a stop block.

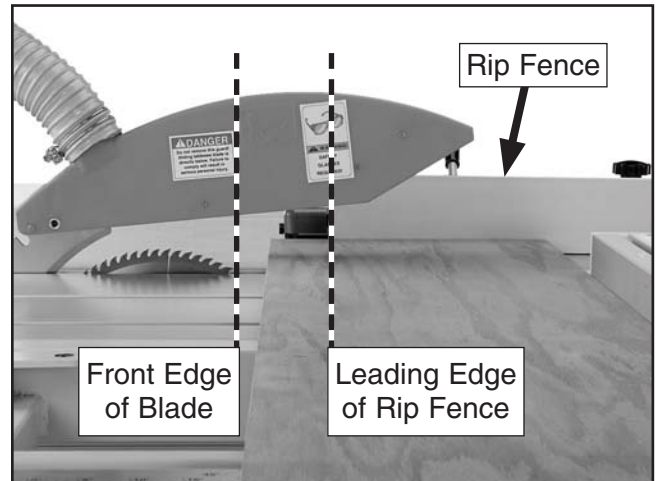

Figure 62. Correct rip fence position when using it as a cut-off gauge.

To perform a crosscutting operation:

1. Install the miter fence in either of the two positions shown in **Figures 60–61**.
2. Adjust the fence angle to 0°, using the angle scale on the miter gauge. If the cut requires extreme precision, adjust the miter fence as described in **Squaring Miter Fence to Blade** on **Page 65**.
3. Adjust the miter fence so it does not extend into the cutting path of the blade.
4. Set the flip stop to the desired width-of-cut.
5. Load the workpiece onto the table saw. The set up should look similar to **Figure 54**.
6. Adjust the height of the main blade approximately $\frac{1}{8}$ "– $\frac{1}{4}$ " above the top of the workpiece.
7. Take all the necessary safety precautions, then perform the cutting operation.



Miter Cutting

The miter fence is graduated in 5° increments and can be angled anywhere between 45°L and 45°R.

The angle of the miter fence is adjusted by loosening the lock handle (**Figure 63**), rotating the fence to the angle shown on the scale, then tightening the lock handle to secure it in place.

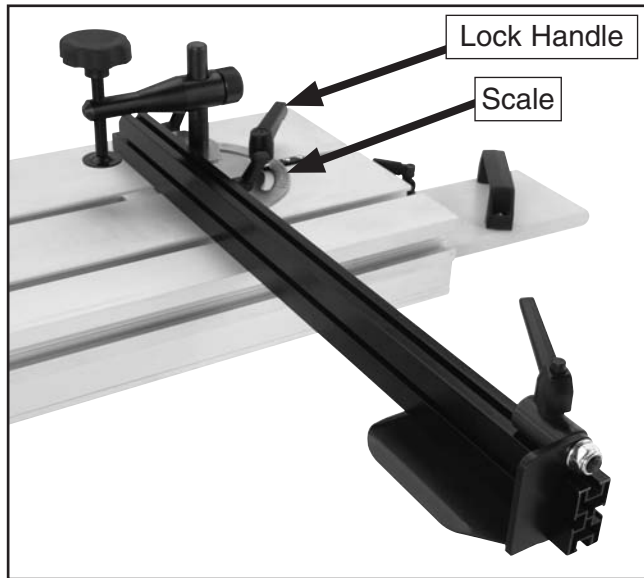

Figure 63. Miter fence.

To perform a miter cut:

1. Install the miter fence on the sliding table.
2. Position the miter fence at the desired angle for the cut and lock it in place. **Figures 64–65** show the miter fence set up for 45° cuts in both directions.
3. Position the flip stop according to the length of the workpiece you want to cut off to the left of the blade.
4. Load the workpiece onto the table saw (similar to **Figure 65**) and perform the cutting operation in the same manner as a crosscut.

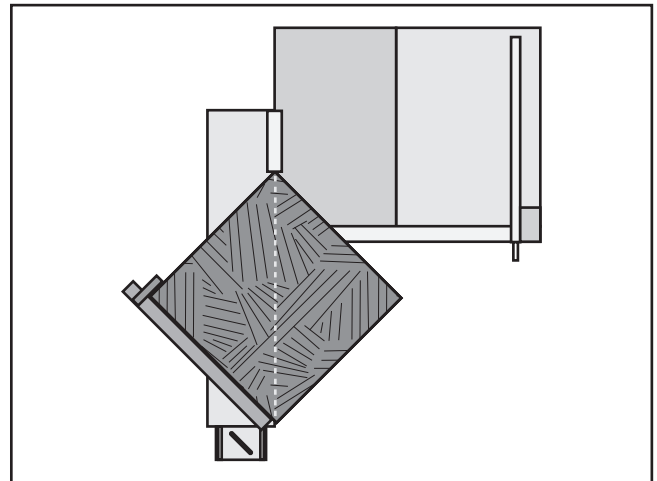

Figure 64. Fence set-up for 45°R cuts.

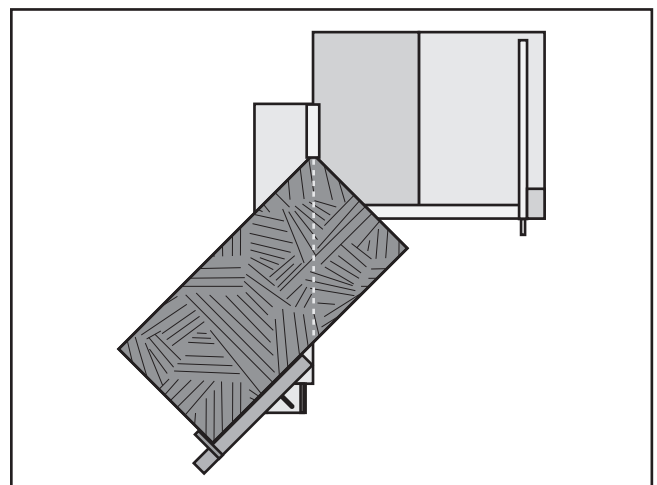

Figure 65. Fence set-up for 45°L cuts.



Dado Cutting

Commonly used in furniture joinery, a dado is a straight channel cut in the face of the workpiece. Dadoes are "non-through" cuts that can be made with a dado blade or a standard saw blade. The **Figure** below shows a cutaway view of a dado cut being made with a dado blade.

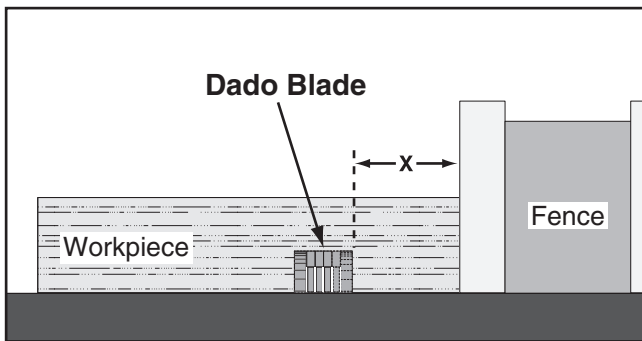

Figure 66. Example of a dado being cut with a dado blade.

This saw can only accept a dado blade with $\frac{5}{8}$ " arbor hole and maximum width of $\frac{13}{16}$ ". If you have any doubts or questions about the size of dado blade you want to install, call our Technical Support before proceeding.

In order to install a dado blade, the scoring blade should be removed and a zero-clearance table insert must be made specifically for the dado blade you will install (see **Figure 67**). Refer to **Zero-Clearance Insert** on **Page 52** for instructions on how to do this.

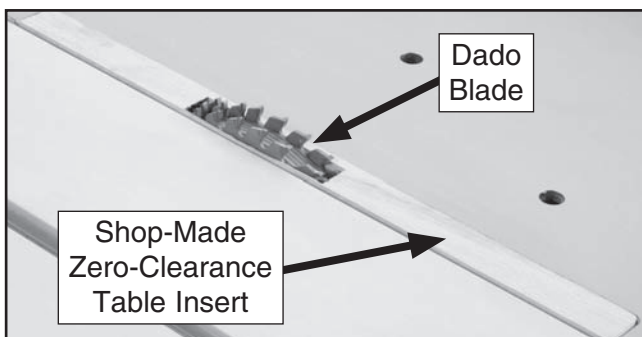

Figure 67. Dado blade raised into shop-made zero-clearance table insert.

If you plan on making dadoes at varying widths, we strongly recommend making a zero-clearance table insert for each thickness of dado blade that will be used.

Installing Dado Blade

1. DISCONNECT SAW FROM POWER!
2. Move the sliding table out of the way to expose the lower blade cover.
3. Remove the standard blade. To loosen the arbor nut, insert the arbor lock tool that came with the saw and turn the arbor nut clockwise (it has left-hand threads).
4. Remove the spacer block installed on the arbor behind the standard blade you removed in **Step 3**. The spacer block is not used when dado blades are installed (see **Figure 68**).

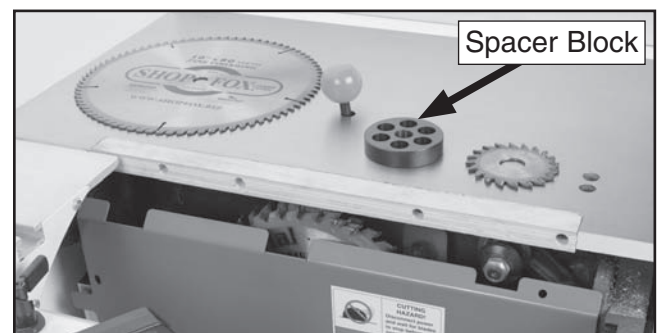

Figure 68. Dado blade installed on saw with new zero-clearance table insert.

5. Assemble/adjust the dado blade system to the desired width of cut, according to the dado blade manufacturer's instructions.
6. Install the dado blade on the arbor shaft, as shown in **Figure 69**.

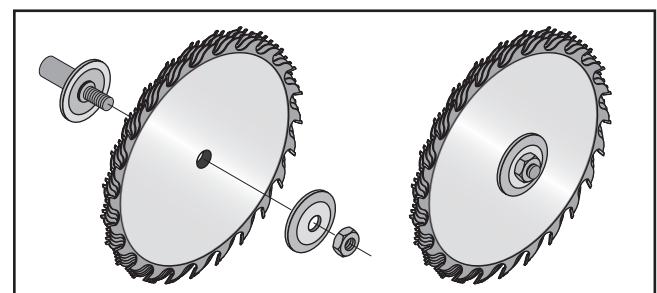

Figure 69. Installing a dado blade.

! WARNING

DO NOT make through cuts with a dado blade. Dado blades are only intended for non-through cuts. Failure to heed this warning could result in serious injury.



Cutting Dados with a Dado Blade

Because dado blades are much wider than standard blades, they place a greater amount of force against the workpiece when cutting. This additional force increases the risk of kickback, requiring the operator to take additional steps when cutting to keep their injury risk at an acceptable level.

!WARNING

Dado blades have a higher risk of kickback than normal blades because their larger size applies stronger forces to the workpiece. This risk increases relative to the depth and width of the cut. To minimize your risk of serious personal injury, ensure that stock is flat and straight, and make multiple light cuts (rather than one deep cut) to achieve the desired cutting depth.

The **Figure** below demonstrates the sequential process of making multiple, light cuts that get progressively deeper. The actual number of cuts used should be determined by workpiece hardness, total dado depth, and feed rate. In general, if you hear the motor slow down during the cut, you are cutting too deep or feeding too fast.

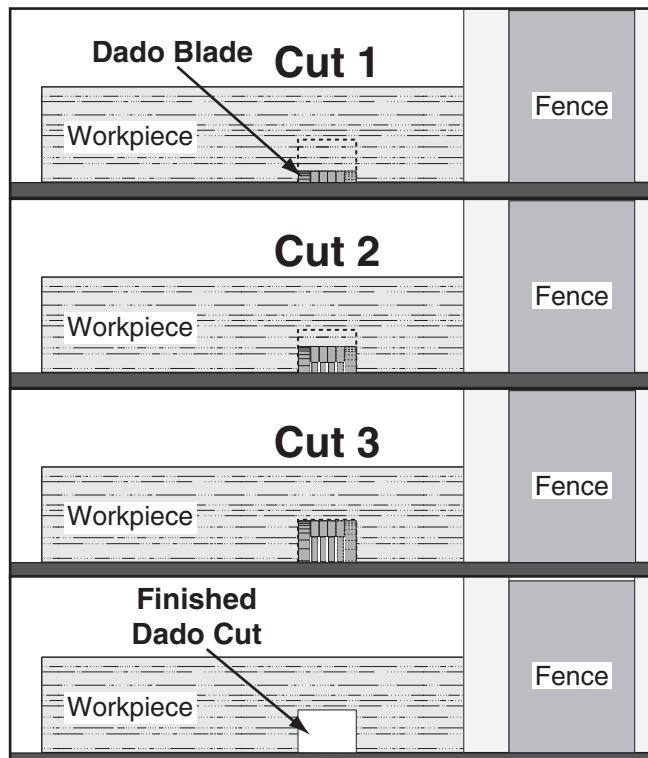

Figure 70. Example of dado being cut with multiple light cuts, instead of one deep cut.

Cutting Dados with a Standard Blade

A ripping blade is typically the best blade to use for cutting dados when using a standard blade because it removes sawdust very efficiently. See **Page 37** for blade details.

To use a standard saw blade to cut dados:

1. DISCONNECT SAW FROM POWER!
2. Mark the width of the dado cut on the workpiece. Include marks on the edge of the workpiece so the cut path can be aligned when the workpiece is lying on the table.
3. Raise the blade up to the desired depth of cut (depth of dado channel desired).
4. Set the saw up for the type of cut you need to make, depending on if it is a rip cut (**Page 37**) or crosscut (**Page 39**).
5. Align the blade to cut one of the dado sides, as shown in **Figure 71**.

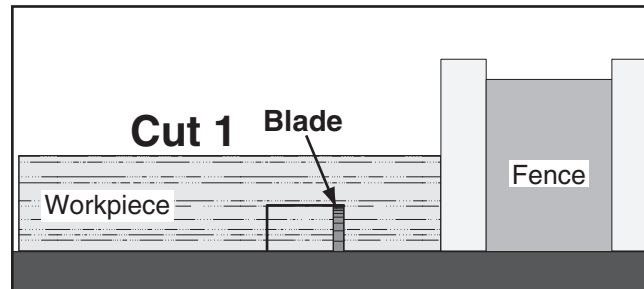

Figure 71. First cut for a single-blade dado.



6. Reconnect the saw to the power source and turn the saw **ON**. Allow the blade to reach full speed, then perform the cutting operation.
7. Repeat the cutting operation on the other side of the dado channel, as in **Figure 72**.

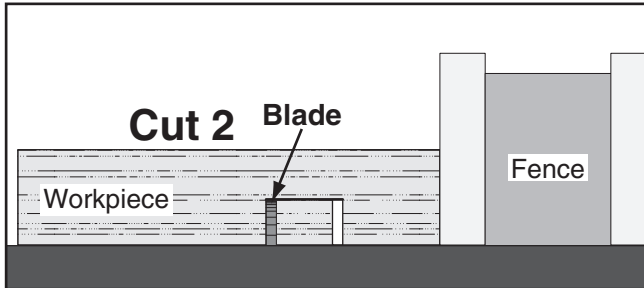

Figure 72. Second cut for a single blade dado.

8. Make additional cuts in the center of the dado to clear out the necessary material. The dado is complete when the channel is completely cleared out.

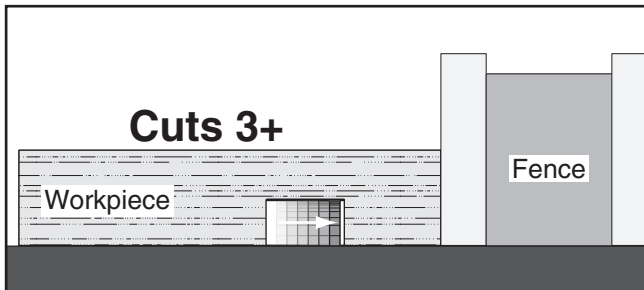

Figure 73. Successive cuts in the middle to complete the dado.

Rabbet Cutting

Commonly used in furniture joinery, a rabbet is an L-shaped groove cut in the edge of the workpiece. Rabbets can be cut with either a dado blade or a standard saw blade.

Rabbet cutting on the edge of the workpiece with a dado blade requires a sacrificial fence (**Figure 74**). Make the sacrificial fence the same length as the fence and $\frac{3}{4}$ " thick. Attach it to the fence with screws or clamps, making sure they are all secure and tight. Raise the blade into the sacrificial fence to the height needed.

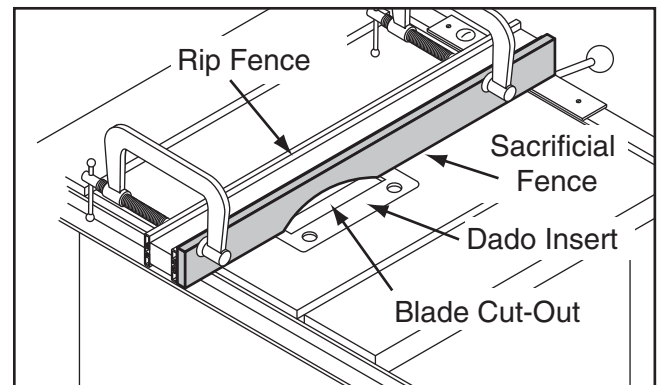

Figure 74. Sacrificial fence.

!WARNING

Dado blades have a higher risk of kickback than normal blades because their larger size applies stronger forces to the workpiece. This risk increases relative to the depth and width of the cut. To minimize your risk of serious personal injury, ensure that stock is flat and straight, and make multiple light cuts (rather than one deep cut) to achieve the desired cutting depth.

!CAUTION

Always use push sticks, featherboards, push paddles and other safety accessories whenever possible to increase safety and control during operations which require that the blade guard to be removed from the saw. **ALWAYS** replace the blade guard after dadoing is complete.



Cutting Rabbets with a Dado Blade

1. DISCONNECT THE SAW FROM POWER!
2. Adjust the dado blade to the height needed for the rabbeting operation. When cutting deep rabbets, take more than one pass to reduce the risk of kickback.
3. Adjust the fence and align the workpiece to perform the cutting operation as shown in **Figure 75**.

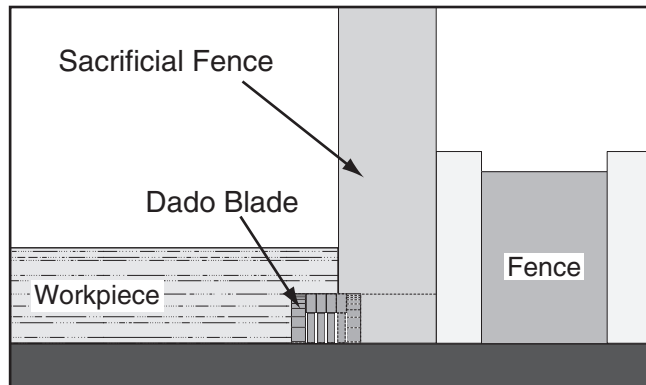

Figure 75. Rabbet cutting with a dado blade.

4. Reconnect the saw to the power source and turn the saw **ON**. When the blade has reached full speed, perform a test cut with a scrap piece of wood.

—If the cut is satisfactory, repeat the cut with the final workpiece.

Cutting Rabbets with a Standard Blade

A ripping blade is typically the best blade to use for cutting rabbets when using a standard blade because it removes sawdust very efficiently. (See **Page 37** for blade details.) Also, a sacrificial fence is not required when cutting rabbets with a standard blade.

To cut rabbets with the standard blade:

1. DISCONNECT SAW FROM POWER!
2. Mark the width of the rabbet cut on the edge of the workpiece, so you can clearly identify the intended cut while it is laying flat on the saw table.

3. Raise the blade up to the desired depth of cut (depth of rabbet channel desired).
4. Adjust the fence so the blade is aligned with the inside of your rabbet channel as shown in **Figure 76**.

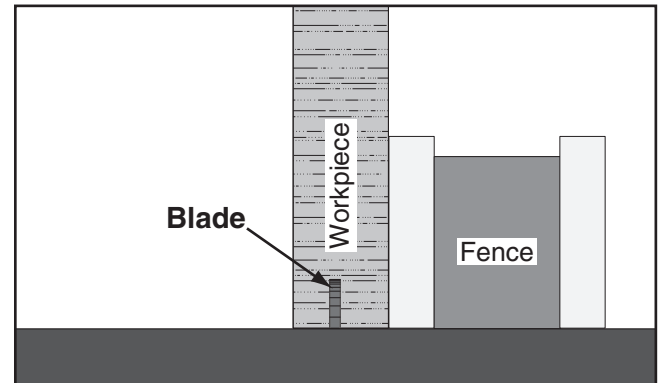

Figure 76. Rabbet cutting with a standard blade.

5. Reconnect the saw to the power source and turn the saw **ON**. When the blade has reached full speed, perform a test cut with a scrap piece of wood.

—If the cut is satisfactory, repeat the cut with the final workpiece.

6. Lay the workpiece on its side, as shown in **Figure 77**, adjust the saw blade height to intersect with the first cut, and perform the second cut to complete the rabbet.

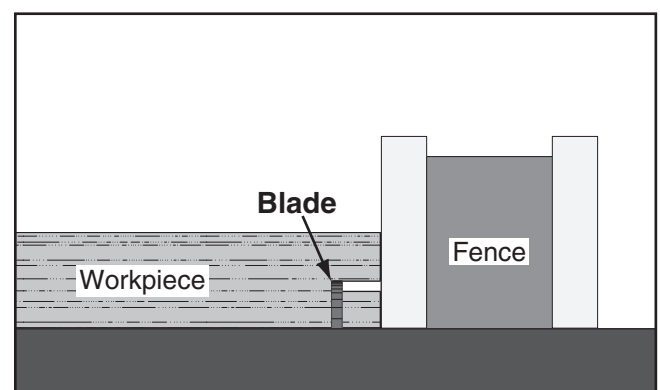

Figure 77. Second cut to create a rabbet.



Resawing

⚠️ WARNING

Resawing operations require proper procedures to avoid serious injury. Extra care must be taken to prevent kickback when resawing. Any tilting or movement of the workpiece away from the fence will cause kickback. Be certain that stock is flat and straight. Failure to follow these warnings could result in serious personal injury.

Resawing is the process of cutting a thick piece of stock into one or more thinner pieces. Although resawing can be done with a table saw, we strongly recommend that you use a bandsaw instead.

A bandsaw is the ideal machine for resawing, and resawing with one is fairly easy and safe. A table saw is not intended for resawing, and resawing with one is difficult and dangerous due to the increased risk of kickback from binding and deep cuts, and the increased risk of injury from having to remove the guard.

If you insist on resawing with a table saw, DO NOT do so without using a resaw barrier and wearing a full face shield. The following instructions describe how to build a resaw barrier that can be used with the rip fence when resawing to reduce the risk injury.

Note: To determine the maximum resawing height for this table saw, find the maximum blade height, then double it and subtract $\frac{1}{8}$ ".

Making Resaw Barrier

The resaw barrier acts in tandem with the rip fence when resawing to provide tall support for the workpiece to minimize the probability of it binding against the blade and causing kickback.

Tools Needed:	Qty
Table Saw	1
Jointer and Planer	Recommended
Clamps	2 Minimum
Drill and Drill Bits	1

Components Needed for Resaw Barrier:

Wood* $\frac{3}{4}$ " x $5\frac{1}{2}$ " x Length of Fence	1
Wood* $\frac{3}{4}$ " x 3" x Length of Fence	1
Wood Screws #8 x 2"	8
Wood Glue	As Needed

* Only use furniture grade plywood or kiln dried hardwood to prevent warping.

To build the resaw barrier:

1. Cut your wood pieces to the size specified above. If you are using hardwood, cut the pieces oversize, then joint and plane them to the correct size to make sure they are square and flat.
2. Pre-drill and countersink four holes approximately $\frac{3}{8}$ " from the bottom of the $5\frac{1}{2}$ " tall wood piece.
3. Glue the end of the 3" board, then clamp the boards at a 90° angle with the larger board in the vertical position, as shown in **Figure 78**, fasten together with the wood screws.

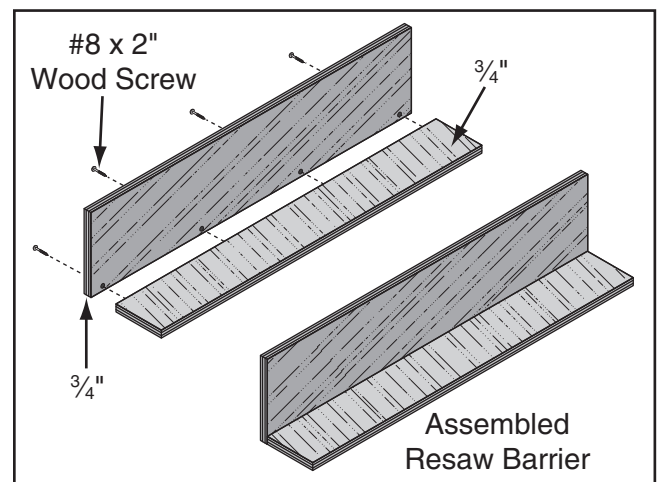

Figure 78. Resaw barrier.



Resawing Operations

The table saw motor is pushed to its limits when resawing. If the motor starts to bog down, slow down your feed rate. Motor overloading and blade wear can be reduced by using a ripping blade. Ripping blades are designed to clear the sawdust quickly.

Components Needed for Resawing:

Zero-clearance Insert	1
Ripping Blade 10".....	1
Clamps	2
Shop Made Auxiliary Fence	1
Shop Made Resaw Barrier	1

!WARNING

You may experience kickback during this procedure. Stand to the side of the blade path and wear safety glasses or a face shield to prevent injury.

To perform resawing operations:

1. DISCONNECT SAW FROM POWER!
2. Install the rip fence in the vertical position.
3. Place the workpiece against the rip fence and slide the resaw barrier against the workpiece. Now clamp the resaw barrier to the top of the table saw (see **Figure 79**).

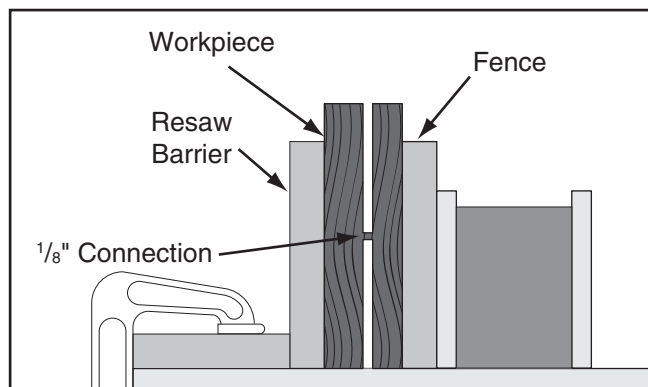

Figure 79. Ideal completed resaw cut.

4. Lower the blade completely below the table, and slide the workpiece over the blade to make sure it moves smoothly and fits between the resaw barrier and fence.
5. Raise the blade approximately an inch, or close to half the height of the workpiece, whichever is less.

!WARNING

Operations requiring the blade guard to be removed increase the risk of accidental contact with the blade. To reduce this risk, use push sticks/paddles and featherboards to keep your hands at a safe distance from the blade throughout the entire cut. Always replace guard after completing the cut!

6. Plug in the table saw, turn it **ON**, and use a push stick to feed the workpiece through the blade using a slow, steady feed rate.
7. Flip the workpiece end for end, keeping the same side against the fence, and run the workpiece through the blade.
8. Repeat **Steps 4–6** until the blade is close to half of the height of the board to be resawn. The ideal completed resaw cut will leave a $\frac{1}{8}$ " connection when the resawing is complete as shown in **Figure 79**. Leaving a $\frac{1}{8}$ " connection will reduce the risk of kickback.
9. Turn **OFF** the table saw, then separate the parts of the workpiece and hand plane the remaining ridge.
10. When finished resawing, remove the resaw barrier and re-install the blade guard/splitter.



SECTION 5: SHOP MADE SAFETY ACCESSORIES

Featherboards

Easily made from scrap stock, featherboards provide an added degree of protection against kickback, especially when used together with push sticks. They also maintain pressure on the workpiece to keep it against the fence or table while cutting, which makes the operation easier and safer because the cut can be completed without the operator's hands getting near the blade. The angled ends and flexibility of the fingers allow the workpiece to move in only one direction.

Making a Featherboard

This sub-section covers the two basic types of featherboards: 1) Those secured by clamps to the table or fence, or 2) those secured by a wood runner that mounts in the table saw miter slot.

Material Needed for Featherboard Mounted with Clamps

- Hardwood $\frac{3}{4}$ " x 3" x 10" (Minimum)
- Hardwood $\frac{3}{4}$ " x 6" x 28" (Maximum) 1

Material Needed for Featherboard Mounted in Miter Slot

- Hardwood $\frac{3}{4}$ " x 3" x 10" (Minimum)
- Hardwood $\frac{3}{4}$ " x 6" x 28" (Maximum) 1
- Hardwood $\frac{3}{8}$ " x (Miter Slot Width) x 5"L 1
- Wing Nut $\frac{1}{4}$ "-20..... 1
- Flat Head Screw $\frac{1}{4}$ "-20 x 2" 1
- Flat Washer $\frac{1}{4}$ "-20..... 1

To make a featherboard:

1. Cut a hardwood board approximately $\frac{3}{4}$ " thick to size. The length and width of the board can vary according to your design. Most featherboards are 10"–28" long and 3"–6" wide. Make sure the wood grain runs parallel with the length of the featherboard, so the fingers you will create in **Step 3** will bend without breaking.

2. Cut a 30° angle at one end of the board.
3. Make a series of end cuts with the grain $\frac{3}{8}$ "– $\frac{1}{4}$ " apart and 2"–3" long, as shown in **Figure 80** (A). Alternatively, start cuts at 2"–3" deep, then make them progressively deeper, as shown in **Figure 80** (B). Cuts made across the grain will result in weak fingers that will easily break.

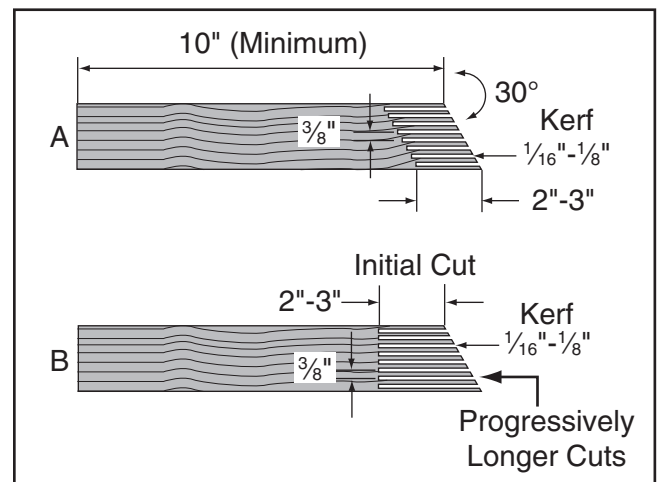

Figure 80. Patterns for featherboards (top view shown).

When complete, the fingers should flex when pushed with moderate pressure. If the fingers do not flex, they are too thick.

Note: We recommend using a bandsaw for making fingers because it tends to be safer. A table saw can be used, but it will over-cut the underside of the ends, produce a thicker kerf, and require you to stop the blade half-way through the cut, which can be dangerous.

If you are securing the featherboard with clamps, no further steps are necessary. Your featherboard is complete! If you are making a featherboard that mounts in the miter slot, continue with **Step 4**.



4. Rout a $\frac{1}{4}$ "– $\frac{3}{8}$ " wide slot 4"–5" long in the workpiece and 1"–2" from the short end of the featherboard (see **Figure 81**).

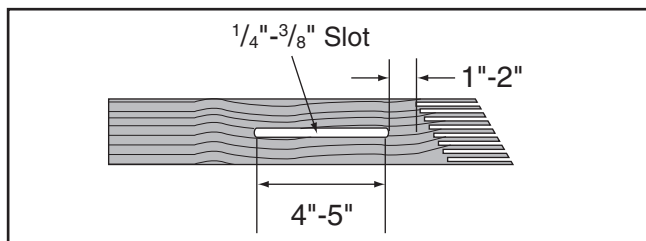

Figure 81. Slot routed in featherboard.

5. Cut a miter bar that will fit in the table miter slot approximately 5" long, as shown in **Figure 82**.

Tip: Consider making the miter bar longer for larger featherboards—approximately half the length of the total featherboard—to support the force applied to the featherboard during use.

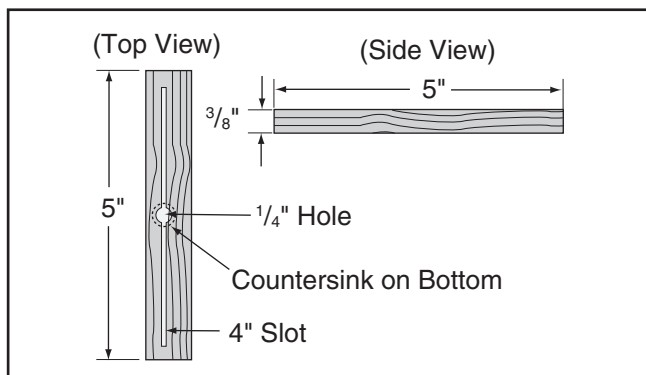

Figure 82. Miter bar pattern.

6. Drill a $\frac{1}{4}$ " hole in the center of the bar, then countersink the bottom to fit a $\frac{1}{4}$ "-20 flat head screw.
7. Mark a 4" line through the center of the countersunk hole in the center, then use a jig saw with a narrow blade to cut it out.
8. Assemble the miter bar and featherboard with a $\frac{1}{4}$ "-20 x flat head screw, flat washer, and a wing nut or a star knob (see **Figure 83**). Congratulations! Your featherboard is complete.

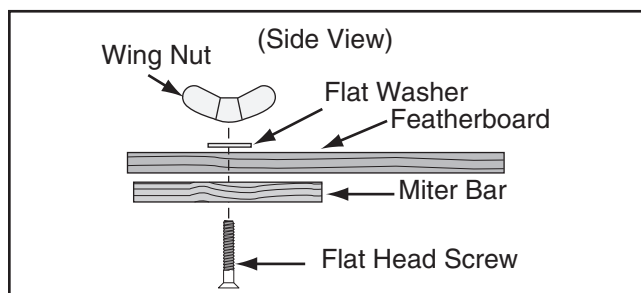

Figure 83. Assembling miter slot featherboard components.

Tip: The length of the flat head screw depends on the thickness of the featherboard—though $1\frac{1}{2}$ " to 2" lengths usually work.

Now, proceed to **Mounting Featherboard in Miter Slot** on **Page 49**.



Mounting Featherboards w/Clamps

1. Lower the saw blade, then adjust the fence to the desired width and secure it.
2. Place the workpiece against the fence, making sure it is 1" in front of the blade.
3. Place a featherboard on the table away from the blade so all fingers point forward and contact the workpiece (see **Figure 84**).

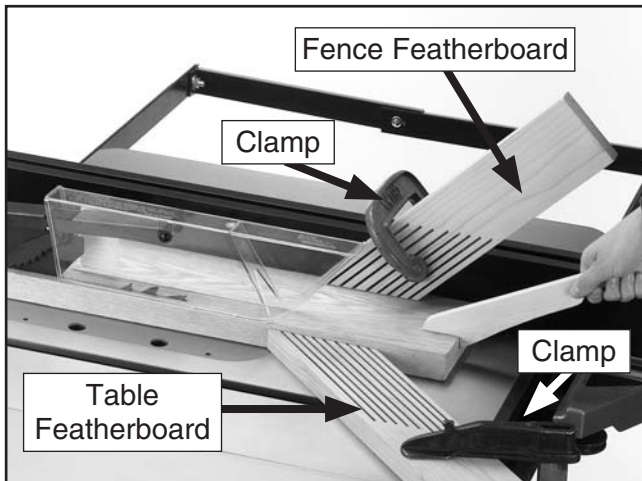

Figure 84. Example of featherboards secured with clamps.

4. Secure the featherboard to the table with a clamp.
5. Check the featherboard by pushing it with your thumb to ensure it is secure.
—If the featherboard moves, tighten the clamp more.
6. Mount a second featherboard to the fence with another clamp (see **Figure 84**), then repeat **Step 5** to ensure it is secure.

Mounting Featherboard in Miter Slot

1. Lower the saw blade, then adjust the fence to the desired width and secure it.
2. Place the workpiece evenly against the fence, making sure it is 1" in front of the blade.
3. Slide the featherboard miter bar into the miter slot, making sure the fingers slant toward the blade, as shown in **Figure 85**.

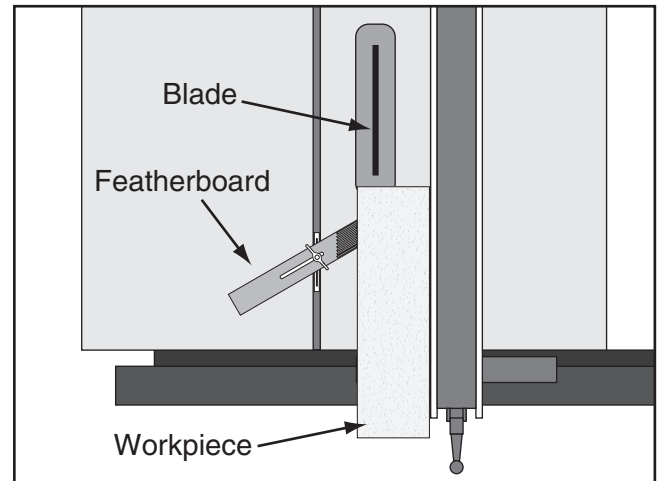

Figure 85. Featherboard installed in miter slot and supporting workpiece for ripping cut.

4. Position the fingered edge of the featherboard against the edge of the workpiece, so that all of the fingers contact the workpiece. Slide the featherboard toward the blade until the first finger is nearly even with the end of the workpiece, which should be 1" away from the blade.
5. Double check the workpiece and the featherboard to ensure they are properly positioned as described in **Step 4**. Then secure the featherboard to the table. Check the featherboard by hand to make sure it is tight.

Note: *The featherboard should be placed firmly enough against the workpiece to keep it against the fence but not so tight that it is difficult to feed the workpiece.*



Push Sticks

When used correctly, push sticks reduce the risk of injury by keeping hands away from the blade while cutting. In the event of an accident, a push stick can also absorb damage that would have otherwise happened to hands or fingers.

Using a Push Stick

Use push sticks whenever your hands will get within 12" of the blade. To maintain control when cutting large workpieces, start the cut by feeding with your hands then use push sticks to finish the cut, so your hands are not on the end of the workpiece as it passes through the blade.

Feeding: Place the notched end of the push stick against the end of the workpiece (see inset **Figure** below), and move the workpiece into the blade with steady downward and forward pressure.

Supporting: A second push stick can be used to keep the workpiece firmly against the fence while cutting. When using a push stick in this manner, only apply pressure before the blade; otherwise, pushing the workpiece against or behind the blade will increase the risk of kickback (see "Push Stick Prohibition Zone" in the **Figure** below).

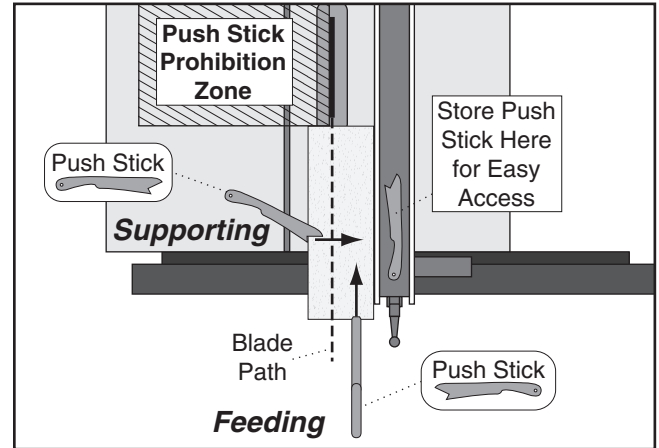

Figure 86. Using push sticks to rip narrow stock.

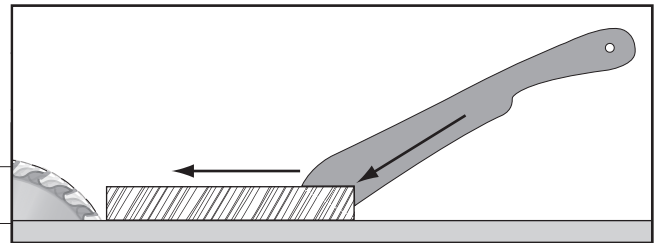
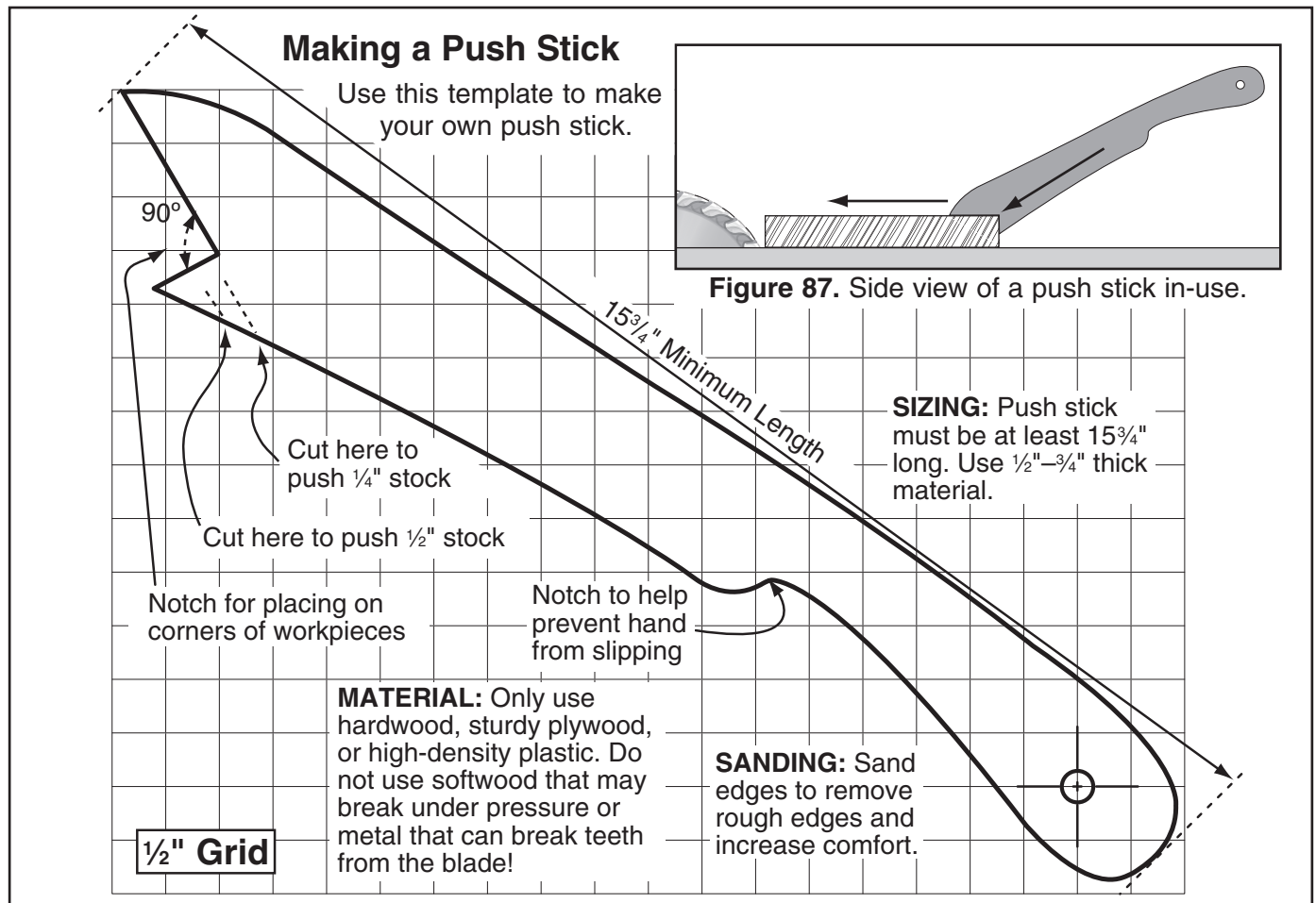

Figure 87. Side view of a push stick in-use.

Figure 88. Template for a basic shop-made push stick (not shown at actual size).



Push Blocks

When used correctly, a push block reduces the risk of injury by keeping hands away from the blade while cutting. In the event of an accident, a push block often takes the damage that would have otherwise happened to hands or fingers.

Using a Push Block

A push block can be used in place of or in addition to a push stick for feeding workpieces into the blade. Due to their design, push blocks allow the operator to apply firm downward pressure on the workpiece that could not otherwise be achieved with a push stick.

The push block design on this page can be used in two different ways (see inset **Figure** below). Typically, the bottom of the push block is used until the end of the workpiece reaches the blade.

The notched end of the push block is then used to push the workpiece the rest of the way through the cut, keeping the operator's hands at a safe distance from the blade. A push stick is often used at the same time in the other hand to support the workpiece during the cut (see "Using a Push Stick" on previous page).

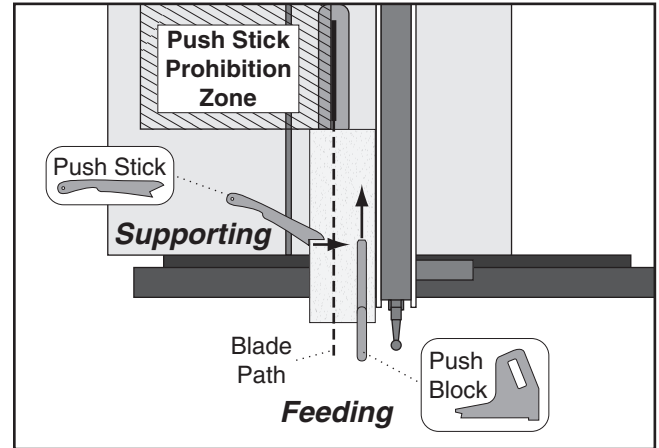

Figure 90. Using a push block and push stick to make a rip cut.

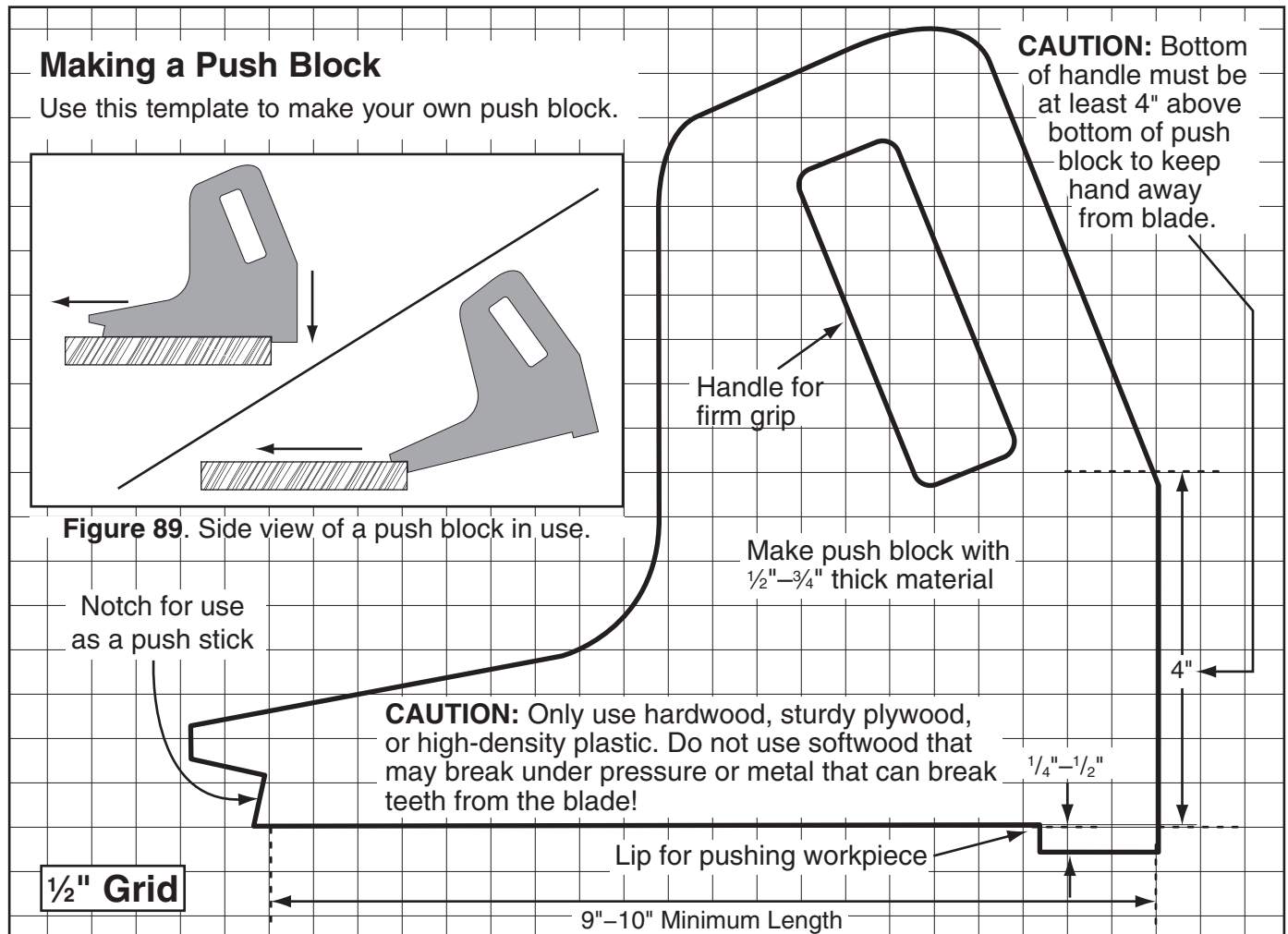

Figure 91. Template for a shop-made push block (shown at 50% of full size).



Zero-Clearance Insert

A zero-clearance insert can be made for the saw in about 30 minutes, and must be made of $\frac{3}{4}$ " furniture quality plywood or a hardwood. (We recommend making at least 6–12 while you are going through the process, so you have plenty on hand for varying blade widths, heights, or angles.

A zero-clearance insert is required if you want to install a dado blade. When a dado blade is installed, the scoring blade and riving knife are removed—as neither will properly perform their intended function.

If you plan to use a standard blade with a zero-clearance insert, additional modifications will need to be made in order to install the scoring blade and riving knife.

! WARNING

If you must use this saw to cut the dimensions of the zero-clearance insert you will fabricate in these instructions, make sure you DO NOT make any cuts while the included table insert is removed. THIS IS DANGEROUS. You must re-install the table insert, reassemble all saw components, and remove all tools before cutting.

Items Needed	Qty
Table Saw	1
Drill Press	1
Sander	1
Drill Bits $\frac{7}{32}$ " and $\frac{13}{32}$ "	1 Each
Plywood/Hardwood Piece 14" x $\frac{11}{16}$ " x $\frac{3}{4}$ "	1
Bandsaw or Jigsaw (Optional)	1
Clamp (Optional)	1

To make a zero-clearance table insert, do these steps:

1. DISCONNECT SAW FROM POWER
2. Lower the main blade all the way, remove the blade guard, riving knife, and scoring blade. After removing the scoring blade, reinstall and tighten the scoring blade flanges and arbor nut.

3. Remove the main blade and the spacer block behind it (see **Figure 92**).



Figure 92. Original table insert and all necessary components removed.

4. Remove the table insert installed on the saw.
5. Cut the new table insert to the exact length of the included table insert and $\frac{11}{16}$ " wide.
6. Use the included table insert as a template, as shown in **Figure 93**, to mark the mounting holes on the new table insert. (Clamping the pieces together while you do this will allow you to ensure the hole spacing is exact.)

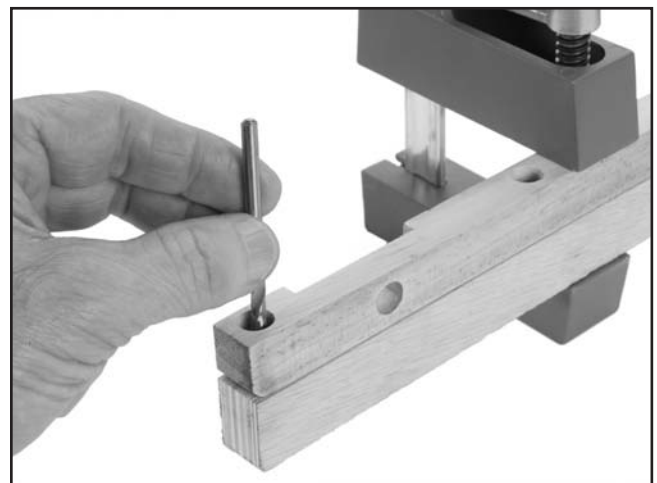

Figure 93. Marking location for mounting holes in new insert.

7. Use the $\frac{7}{32}$ " drill bit to drill holes completely through the new table insert.
8. Install the $\frac{13}{32}$ " drill bit and use the included table insert as a guide to set the depth stop on your drill press to countersink the holes.



- Countersink the holes you drilled in **Step 7** (see **Figure 94**), so the heads of the mounting screws can be recessed into the table insert when installed.

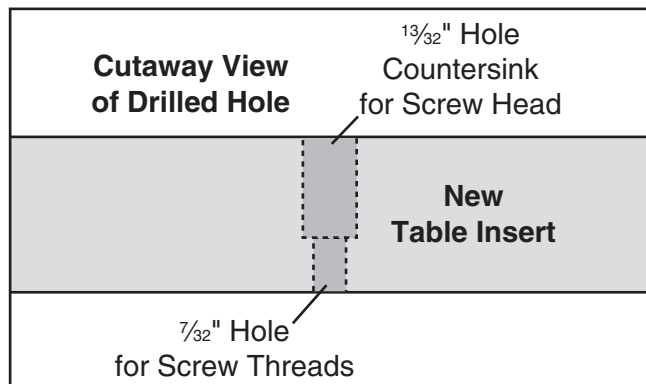

Figure 94. Countersinking mounting holes.

- Install the blade you will use to cut the insert, making sure the blade flange is used on the front of the blade behind the arbor nut, then lower the blade completely.
- Test fit the new table insert in the table, then sand the corners or trim the ends as necessary to get a precise fit.
- Mount the new table insert into the table and check to make sure that it is flush with the top of the table. If necessary, remove the insert and sand the top of it down until it will mount up flush with the table top (see **Figure 95**).



Figure 95. New zero-clearance table insert installed to be cut with a dado blade.

- (This step only for standard blades.)* Use a bandsaw or jigsaw to cut slots or notches that will allow the riving knife to be installed with minimal open space around it. If you plan to use the scoring knife, do the same for that blade (we do not recommend using the scoring blade to cut the slot in the insert because the adjustment screw is inside the cabinet).

- Close the cover over the blade and move the sliding table to the center of the saw.
- Connect the saw to power, start the motor, and slowly raise the blade into the zero-clearance table insert (see **Figure 96**) only as high as you intend to cut with the insert.

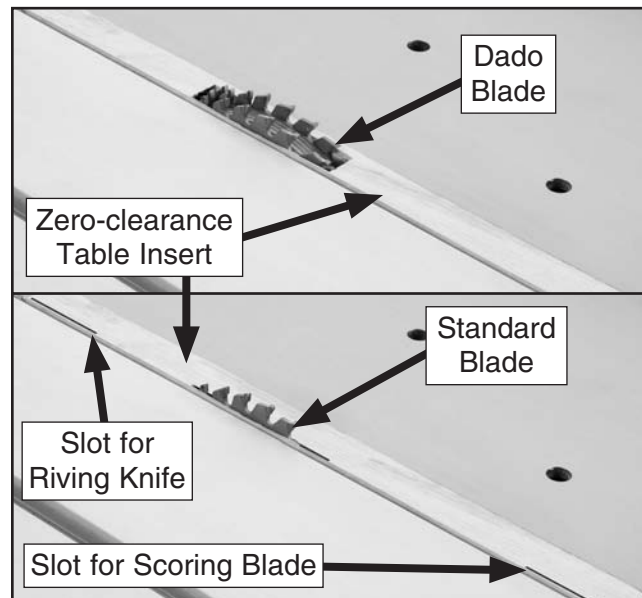

Figure 96. Zero-clearance table inserts for dado and standard blades.

Outfeed Table

One of the best accessories for improving the safety and ease of using a table saw is simply placing a large table (outfeed table) behind the saw to catch the workpiece.



Figure 97. Example of outfeed table.



Narrow-Rip Auxiliary Fence & Push Block

There are designs for hundreds of specialty jigs that can be found in books, trade magazines, and the internet. These types of jigs can greatly improve the safety and consistency of cuts. They are particularly useful during production runs when dozens or hundreds of the same type of cut need to be made.

The narrow-rip auxiliary fence and push block system shown in this section is an example of a specialty jig that can be made to increase the safety of very narrow rip cuts.

Making a Narrow-Rip Push Block for an Auxiliary Fence

1. Cut a piece of $\frac{1}{2}$ " thick plywood $5\frac{1}{4}$ " wide and as long as your table saw fence; cut a piece of $\frac{3}{4}$ " thick hardwood 3" wide and as long as your table saw fence (see **Figure 98**).

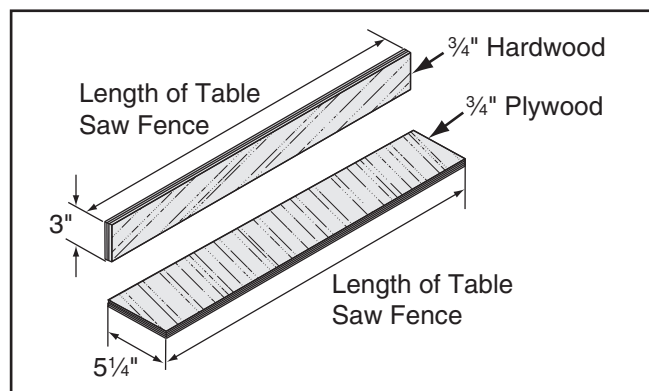

Figure 98. Auxiliary fence dimensions.

Note: We recommend cutting the hardwood board oversize, then jointing and planing it to the correct size to make sure the board is square and flat. Only use furniture grade plywood or kiln dried hardwood to prevent warping.

2. Pre-drill and countersink eight pilot holes $\frac{3}{8}$ " in from the edge of the $5\frac{1}{4}$ " wide board, then secure the boards together with eight #8 x $1\frac{1}{2}$ " wood screws, as shown in **Figure 99**.

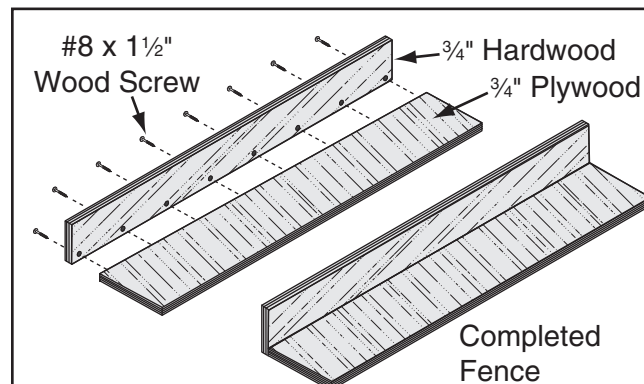

Figure 99. Location of pilot holes.

3. Using the $\frac{1}{2}$ " material you used in the previous steps, cut out pieces for the push block per the dimensions shown in **Figure 100**; for the handle, cut a piece 10" long by 5"–9" high and shape it as desired to fit your hand.

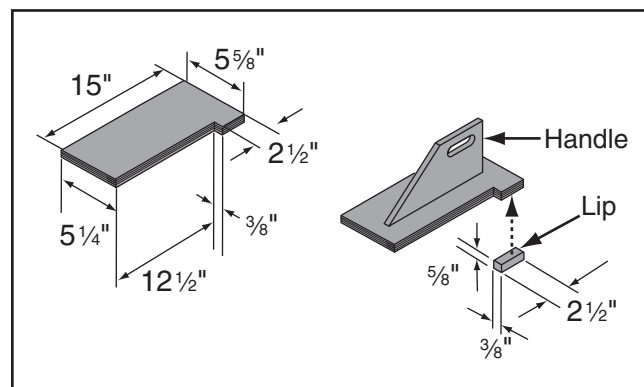

Figure 100. Push block dimensions and construction.

4. Attach the handle to the base with #8 x $1\frac{1}{2}$ " wood screws, and attach the lip to the base with cyanoacrylate type wood glue.



Using the Auxiliary Fence and Push Block

1. Place the auxiliary fence on the table and clamp it to the fence at both ends, then adjust the distance between the auxiliary fence and the blade—this determines how wide the workpiece will be ripped (see **Figure 101**).

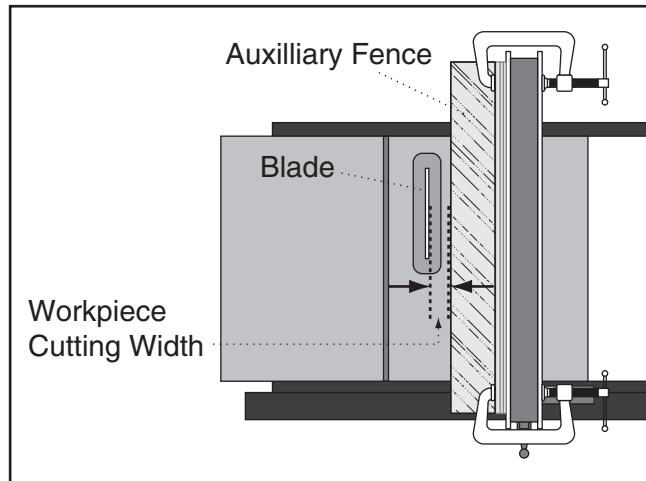
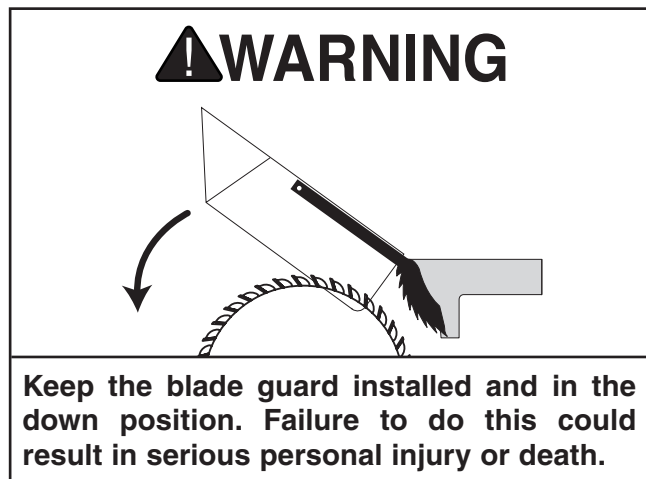

Figure 101. Adjusting ripping distance between blade and auxiliary fence.

2. Install the blade guard.



3. Place the workpiece 1" behind the blade and evenly against the table and the auxiliary fence.

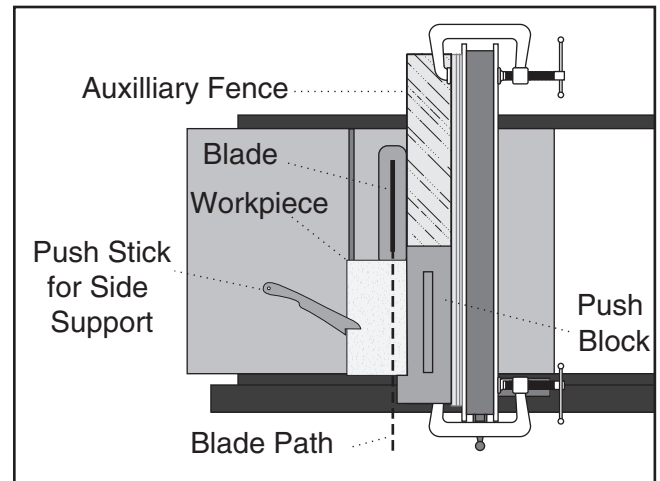

Figure 102. Push block in position to push workpiece through blade.

4. Turn the saw **ON**, then begin ripping the workpiece using a push stick for side support.
5. As the workpiece nears the end of the cut, place the push block on the auxiliary fence with the lip directly behind the workpiece, then release the push stick just before the blade.
6. Guide the workpiece the rest of the way through the cut with the push block, as shown in **Figure 103**.

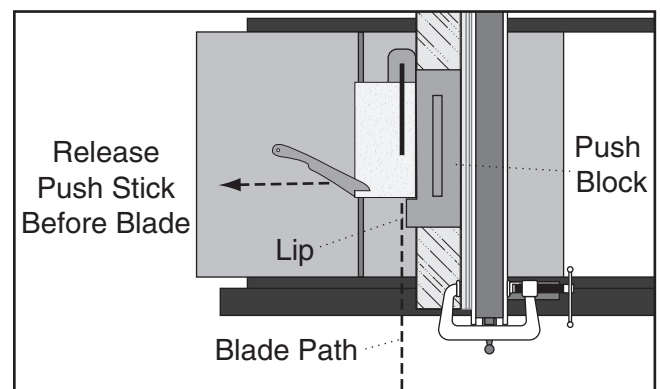

Figure 103. Ripping with push block.

! WARNING

Turn **OFF** the saw and allow the blade to come to a complete stop before removing the cut-off piece. Failure to follow this warning could result in serious personal injury.



SECTION 6: AFTERMARKET ACCESSORIES FROM GRIZZLY

⚠️ WARNING

Some aftermarket accessories can be installed on this machine that could cause it to function improperly, increasing the risk of serious personal injury. To minimize this risk, only install accessories recommended for this machine by Grizzly.

NOTICE

Refer to the newest copy of the Grizzly Catalog for other accessories available for this machine.

Call 1-800-523-4777 To Order

10" Blades

- H5190—Razor Variable Tooth Carbide 50T
- H9146—Heavy-Duty ATB Carbide Tip 60T
- G2804—Commercial Solid Surface Blade 60T
- H9147—Heavy-Duty ATB Carbide Tip 80T
- H9360—Commercial Melamine Blade 80T
- H9148—Heavy-Duty ATB Carbide Tip 100T

These blades work especially well for most sliding table saw applications and are manufactured for heavy-duty, industrial use.

T21382—Scoring Blade

Replacement scoring blade for G0700. Measures 80mm in diameter with 22mm arbor hole. Blade is a solid, one-piece wedge-type blade. Kerf width is controlled by changing the height of the exposed portion of the blade from the table.

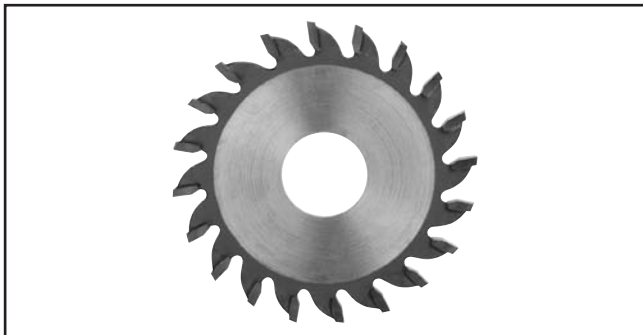

Figure 104. T21382 Scoring Blade.

- G5562—SLIPIT® 1 Qt. Gel
- G5563—SLIPIT® 12 oz Spray
- G2871—Boeshield® T-9 12 oz Spray
- G2870—Boeshield® T-9 4 oz Spray
- H3788—G96® Gun Treatment 12 oz Spray
- H3789—G96® Gun Treatment 4.5 oz Spray



Figure 105. Recommended products for protecting unpainted cast iron/steel part on machinery.

G7315Z—Super Heavy-Duty SHOP FOX® Mobile Base

This patented, super heavy-duty mobile machine base is the strongest mobile base on the market. 18" x 24½" minimum and adjusts to 28½" x 33½" maximum. 1200 lb. capacity. This base is extremely stable with outrigger type supports and a four wheel system. Weighs 38 lbs.



Figure 106. G7315Z SHOP FOX® Mobile Base.



- T20501—Face Shield Crown Protector 4"
- T20502—Face Shield Crown Protector 7"
- T20503—Face Shield Window
- T20452—"Kirova" Anti-Reflective S. Glasses
- T20451—"Kirova" Clear Safety Glasses
- H0736—Shop Fox® Safety Glasses
- H7194—Bifocal Safety Glasses 1.5
- H7195—Bifocal Safety Glasses 2.0
- H7196—Bifocal Safety Glasses 2.5



Figure 107. Eye protection assortment.

- H2499—Small Half-Mask Respirator
- H3631—Medium Half-Mask Respirator
- H3632—Large Half-Mask Respirator
- H3635—Cartridge Filter Pair P100

Wood dust has been linked to nasal cancer and severe respiratory illnesses. If you work around dust everyday, a half-mask respirator can be a lifesaver. Also compatible with safety glasses!



Figure 108. Half-mask respirator with disposable cartridge filters.

- G1163—1HP Dust Collector
- G3591—30 Micron Replacement Bag
- H4043—3.0 Micron Upgrade Bag

Excellent point-of-use dust collector that can be used next to the machine with minimal ducting. Specifications include 450 CFM, 2.8" static pressure, and 30 micron filter (upgradable to 3.0 micron). Features 1HP, 110V/220V, 14A/7A motor.



Figure 109. G1163 1HP dust collector.

- H8003—Hydraulic Lifting Table - 450 lbs.

This rugged and affordable lifting table allows you to lift stacks of sheet goods right up to the table saw table with minimal effort. Features 39³/₈" x 19³/₄" table, 39¹/₂" maximum table height, 8" fixed and swivel casters with brakes.



Figure 110. Model H8003 Hydraulic Lifting Table.



SECTION 7: MAINTENANCE

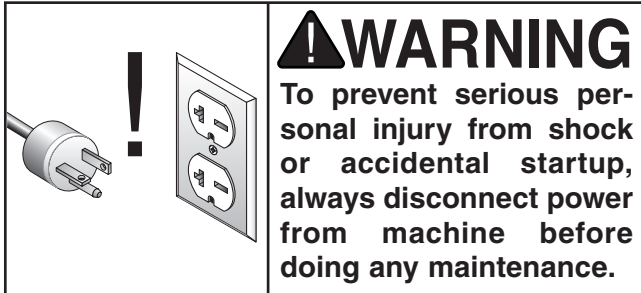

Schedule

The frequency of maintenance necessary for any machine will always depend on the operating conditions and environment. The schedule below is a basic guideline for keeping your machine in proper operating condition. Always repair any adverse conditions immediately upon discovery.

Daily (Ongoing)

- Loose mounting bolts.
- Worn or damaged saw blades.
- Worn or damaged switches or wires.
- Any other unsafe condition.

Weekly

- Clean sliding table surface and grooves.
- Lubricate the sliding table ways (**Page 59**).
- Clean the cast iron saw table.
- Clean the sliding table roller guideways.
- Clean the rip fence.
- Clean the rip fence bracket and rail.

Monthly

- Clean/vacuum dust buildup from inside cabinet and off motor.
- Check V-belt tension, damage, or wear.

Every 6–12 Months

- Lubricate the trunnions (**Page 59**).
- Lubricate the elevation and tilt leadscrews (**Page 59**).

Note: To ensure optimum power transmission from the motor to the blades, the V-belts must be in good condition (free from cracks, fraying and wear) and operate under proper tension.

Cleaning

Cleaning the Model G0700 is relatively easy. Vacuum excess wood chips and sawdust from the table saw and inside the cabinet. Wipe off the remaining dust with a dry cloth.

Use compressed air (make sure to wear safety glasses and a respirator when doing this) to blow dust from between the two sections of the sliding table. If any resin has built up, use a resin dissolving cleaner to remove it. Treat all unpainted cast iron and steel with a non-staining lubricant after cleaning.

Unpainted Cast Iron

Protect the unpainted cast iron surfaces on the table by wiping the table clean after every use—this ensures moisture from wood dust does not remain on bare metal surfaces. DO NOT clean cast iron with water or it will rust!

Keep tables rust-free with regular applications of products like G96® Gun Treatment, SLIPIT®, or Boeshield® T-9 (see **Page 56** for more details).



Lubrication

Bearings: The bearings are sealed and pre-lubricated; they require no lubrication.

Trunnions: Use multi-purpose grease in the trunnion grooves (**Figure 112**) every 6–12 months, depending on the frequency of use. To grease the blade height trunnion, move the blade height all the way down and smear a dab of grease into the trunnion groove, behind the plate shown in **Figure 112**, then move the blade up all the way, then down all the way to spread the grease.

To grease the blade tilt trunnions, move the sliding table out of the way and open the blade guard. Tilt the blade to 90°. From the front of the saw, smear a dab of grease in the front of the trunnion grooves on both sides. Now, tilt the blade to 45° and reach inside the cabinet and smear a dab of grease into the back of the trunnion grooves on both sides. Tilt the blade back and forth to distribute the grease evenly.

Leadscrews: Use multi-purpose grease on the leadscrews (**Figure 112**) every 6-12 months, at the same time you lubricate the trunnions. Wipe the leadscrews clean with a dry rag and brush a light coat of new grease on them with a clean, dry brush. Only grease the area of the leadscrew between the stop nuts. Move the blade height and tilt back and forth to distribute the grease evenly.

Sliding Table Ways & Rip Fence Rail: Wipe on a light machine oil (such as Boeshield shown on **Page 56**) down the entire length of the sliding table steel rods (**Figure 111**) and rip fence rail.



Figure 111. Sliding table ways.

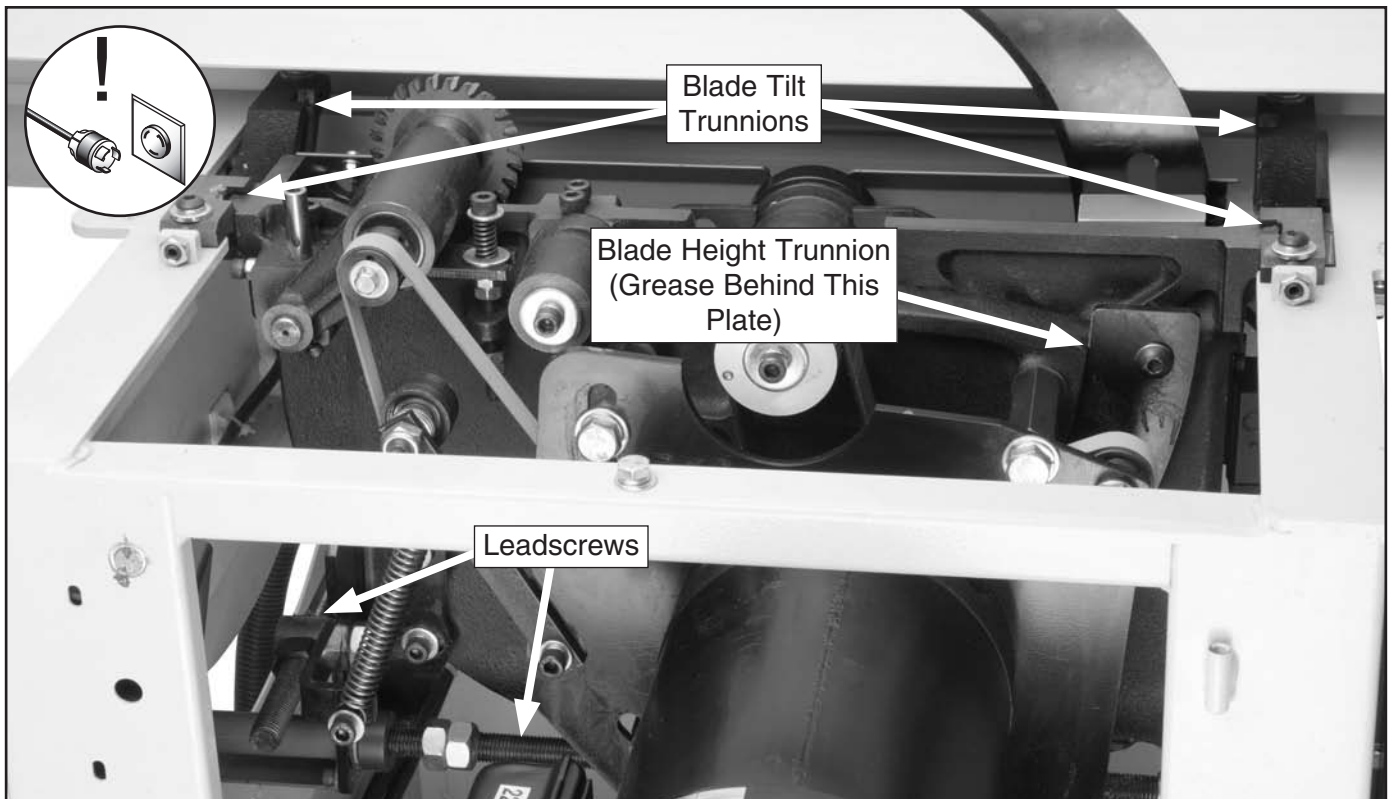

Figure 112. Lubrication locations (table removed for clarity).



SECTION 8: SERVICE

Review the troubleshooting and procedures in this section to fix or adjust your machine if a problem develops. If you need replacement parts or you are unsure of your repair skills, then feel free to call our Technical Support at (570) 546-9663.

Troubleshooting



Motor & Electrical

Symptom	Possible Cause	Possible Solution
Machine does not start or a breaker trips.	<ol style="list-style-type: none"> 1. Stop push-button is engaged/faulty. 2. Power supply switched OFF or is at fault. 3. Motor connection wired incorrectly. 4. Thermal overload relay has tripped. 5. Wall fuse/circuit breaker is blown/tripped. 6. Contactor not getting energized/has burnt contacts. 7. Wiring is open/has high resistance. 8. Motor ON button or ON/OFF switch is at fault. 9. Motor is at fault. 	<ol style="list-style-type: none"> 1. Rotate clockwise slightly until it pops out/replace it. 2. Ensure power supply is switched on; ensure power supply has the correct voltage. 3. Correct motor wiring connections. 4. Wait for it to cool down, then it will reset automatically. If necessary, disconnect power and reset manually by pushing reset button inside switch. 5. Ensure circuit size is suitable for this machine; replace weak breaker. 6. Test for power on all legs and contactor operation. Replace unit if faulty. 7. Check for broken wires or disconnected/corroded connections, and repair/replace as necessary. 8. Replace faulty ON button or ON/OFF switch. 9. Test/repair/replace.
Machine stalls or is underpowered.	<ol style="list-style-type: none"> 1. Feed rate/cutting speed too fast for task. 2. Workpiece material is not suitable for this machine. 3. Belt(s) slipping. 4. Motor connection is wired incorrectly. 5. Motor bearings are at fault. 6. Start delay module is at fault. 7. Motor is at fault. 	<ol style="list-style-type: none"> 1. Decrease feed rate/cutting speed. 2. Only cut wood products; make sure moisture content is below 20% and there are no foreign materials in the workpiece. 3. Replace bad belt(s), align pulleys, and re-tension. 4. Correct motor wiring connections. 5. Test by rotating shaft; rotational grinding/loose shaft requires bearing replacement. 6. Adjust to correct delay; replace module. 7. Test/repair/replace.



Symptom	Possible Cause	Possible Solution
Machine has vibration or noisy operation.	<ol style="list-style-type: none"> 1. Motor or component is loose. 2. Blade is at fault. 3. Belt(s) worn or loose. 4. Pulley is loose. 5. Motor mount loose/broken. 6. Machine is incorrectly mounted or sits unevenly. 7. Arbor pulley is loose. 8. Motor fan is rubbing on fan cover. 9. Arbor bearings are at fault. 10. Motor bearings are at fault. 	<ol style="list-style-type: none"> 1. Inspect/replace stripped or damaged bolts/nuts, and re-tighten with thread locking fluid. 2. Replace warped, bent, or twisted blade; resharpen dull blade. 3. Inspect/replace belts (refer to Page 62). 4. Realign/replace shaft, pulley, setscrew, and key as required. 5. Tighten/replace. 6. Tighten/replace anchor studs in floor; relocate/shim machine. 7. Retighten/replace arbor pulley with shaft and thread locking liquid. 8. Replace dented fan cover; replace loose/damaged fan. 9. Replace arbor housing bearings; replace arbor. 10. Test by rotating shaft; rotational grinding/loose shaft requires bearing replacement.

Operation

Symptom	Possible Cause	Possible Solution
Workpiece has burned edges, binds, or kicks back.	<ol style="list-style-type: none"> 1. Sliding table is not parallel to blade. 2. Riving knife is not aligned with the blade. 3. Blade is warped. 	<ol style="list-style-type: none"> 1. Adjust sliding table parallel with the blade (Page 64). 2. Adjust the riving knife to align it with the main blade. 3. Replace the blade.
Workpiece has chip out on the bottom edge.	<ol style="list-style-type: none"> 1. Scoring blade height is incorrect. 2. Scoring blade is not aligned with the main blade. 3. Scoring blade kerf does not match the main blade. 	<ol style="list-style-type: none"> 1. Adjust the height of the scoring blade. 2. Align the scoring blade (Page 36). 3. Adjust the scoring blade kerf (Page 36).
Cuts are not square.	<ol style="list-style-type: none"> 1. Sliding table is not parallel to blade. 2. Rip fence is not parallel to blade. 3. Miter fence is not perpendicular to the blade. 	<ol style="list-style-type: none"> 1. Adjust the sliding table (Page 64). 2. Adjust the rip fence parallel to blade. 3. Adjust the miter fence perpendicular to the blade (Page 65).
Fence hits table top when sliding across table.	<ol style="list-style-type: none"> 1. Front rail is too low. 2. Rip fence roller is too low. 	<ol style="list-style-type: none"> 1. Raise the front rail. 2. Adjust the rip fence roller.
Blade does not reach 90°, or blade does not reach 45°.	<ol style="list-style-type: none"> 2. Blade tilt stop bolts are out of adjustment. 	<ol style="list-style-type: none"> 2. Adjust the tilt stop bolts (Page 63).
The rip fence scale is not accurate.	<ol style="list-style-type: none"> 1. The rip fence scale is out of calibration or was not set up correctly. 	<ol style="list-style-type: none"> 1. Adjust the rip fence scale so it is accurately calibrated with the blade.
Handwheels for blade adjustments will not turn or are difficult to turn.	<ol style="list-style-type: none"> 1. Shipping braces still attached. 2. Lock knob is tight. 3. Gears caked with dust. 	<ol style="list-style-type: none"> 1. Remove shipping braces. 2. Release the lock knob. 3. Clean out dust and grease the gears.



Belt Replacement

Main Belt Replacement

1. DISCONNECT SAW FROM POWER!
2. Tilt the blade to 45° and lower it as far as it will go.
3. Remove the motor cabinet door.
4. Loosen the pivot bolt and two adjustment bolts (**Figure 113**).

Note: DO NOT loosen these bolts more than 1/2" or you run the risk of the motor mount bolts coming out of their holes, which will be difficult to thread back in.

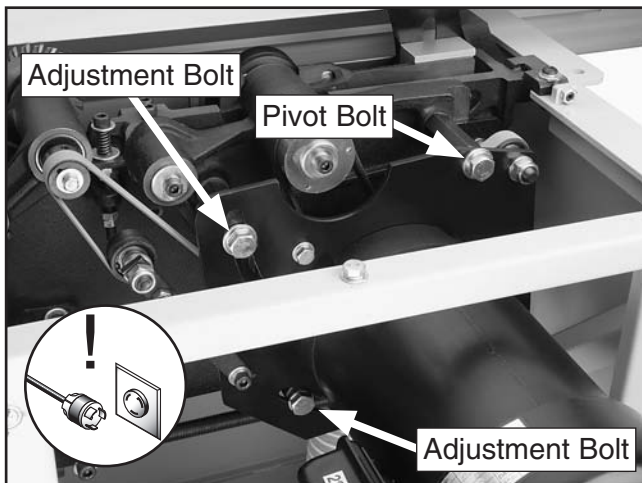

Figure 113. Main blade belt tension controls.

5. Push and hold the motor all the way up to relieve tension on the belt, remove the belt from the top pulley, and squeeze it between the lower pulley and casting.
6. Fit the new belt onto the pulleys in the same manner that you removed the old belt.
7. Push down on the motor with one hand, and tighten the adjustment and pivot bolts with the other hand or have someone help you. The belt should be tight enough that it only deflects approximately 1/4" when pushed in the center with your thumb or index finger.
8. Replace the motor cabinet door.

Scoring Belt Replacement

1. DISCONNECT SAW FROM POWER!
2. Tilt the blade to 45° and lower it as far as it will go.
3. Remove the motor cabinet door.
4. Pull the tensioner away from the scoring belt (**Figure 114**) to relieve belt tension and remove the scoring belt from the pulleys.

Note: Turn the belt sideways to squeeze the flat part through the small gap between the bottom pulley and the casting.

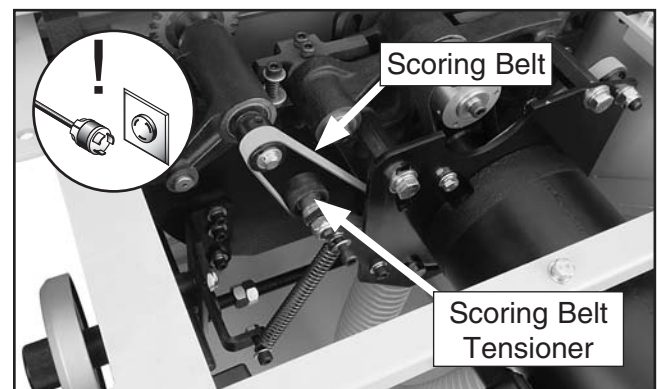

Figure 114. Replacing the scoring motor belt.

5. Put the new scoring belt on the pulleys as shown in **Figure 115**, and push the tensioner against the scoring belt to take up any slack.

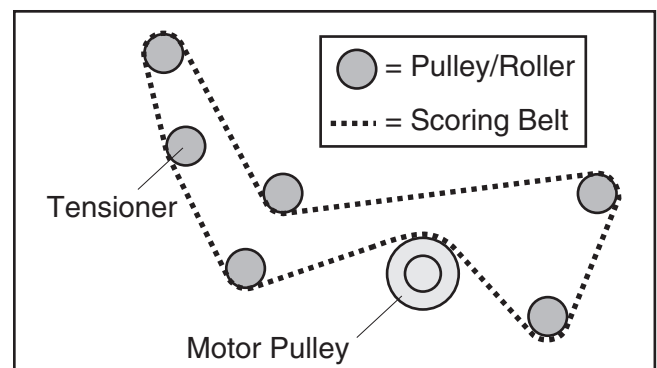

Figure 115. Scoring belt installation configuration.

6. Replace the motor cabinet door.



Blade Tilt Calibration

The blade tilt is calibrated at the factory, but can be recalibrated if it changes during the life of the machine. The 0° stop positions the blade square to the table.

0° Stop

1. DISCONNECT SAW FROM POWER!
2. Move the blade tilt to 0°, and raise the main blade as high as it will go.
3. Use a machinist's square to check if the blade is square to the table.

—If the blade is not square to the table, loosen the two set screws that secure the 0° tilt stop nut shown in **Figure 116**.

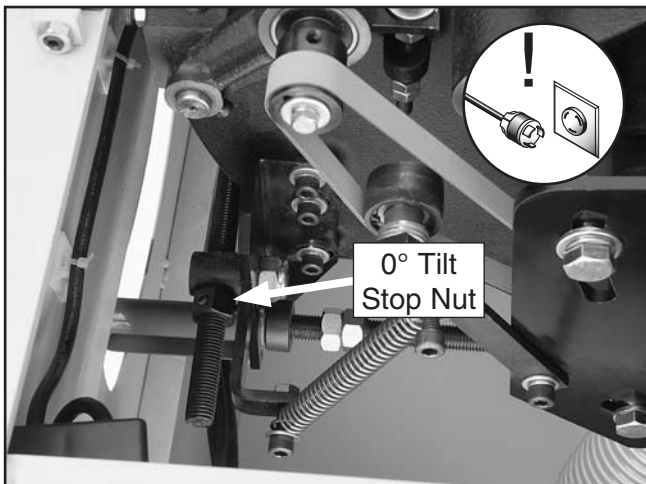

Figure 116. Blade tilt stop nut (0°).

4. Loosen the set screws and adjust the stop nut. Recheck the blade tilt and adjust as many times as necessary until the blade is square to the table.
5. Tighten the two set screws in the stop nut.
6. Check the blade tilt pointer mechanism to ensure that it points to 0°.

—If the blade tilt pointer shows an incorrect tilt, adjust it by loosening the cap screws, rotating the pointer until it points to 0°, then tightening the cap screws.

45° Stop

1. DISCONNECT SAW FROM POWER!
2. Adjust the blade angle until you hit the 45° positive stop and check the blade angle with a 45° square.

—If the blade is not 45° to the table, loosen the two set screws that secure the 45° tilt stop nut shown in **Figure 117**. (This nut can also be accessed from the front of the saw by moving the sliding table all the way forward.)

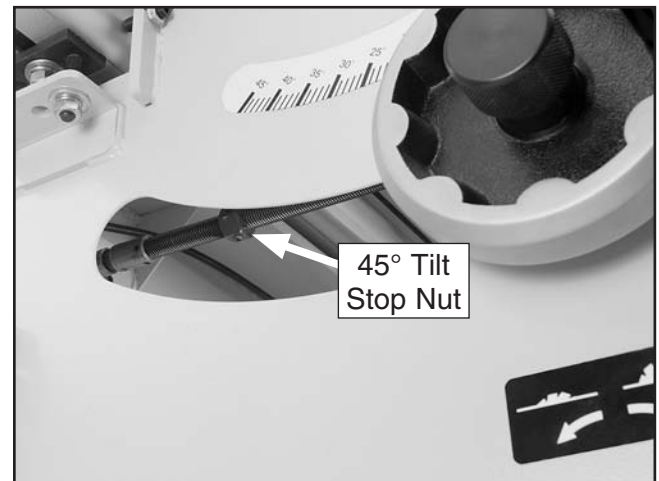

Figure 117. 45° Blade tilt stop nut.

3. Adjust the stop nut and recheck the blade tilt as many times as necessary until the blade is 45° to the table.
4. Tighten the two set screws in the stop nut.



Sliding Table Parallel Adjustment

The table is calibrated at the factory, but can be adjusted slightly if it is not parallel to the blade.

Tools Needed:	Qty
Felt Tip Pen.....	1
90° Square	1
Precise Measuring Tool.....	1
Wrench 17mm.....	1
Hex Wrench 5mm.....	1

To adjust the sliding table parallel with the main blade:

1. DISCONNECT SAW FROM POWER!
2. Move the blade tilt to 0° (blade 90° to table), and raise the main blade up to the maximum height.
3. Mark one of the blade teeth with a felt tip pen. This will be your reference point when taking measuring points, so you take them in the same location each time.
4. Move the sliding table all the way back, and measure the distance "A" in **Figure 118**, between the marked tooth and the edge of the miter slot.

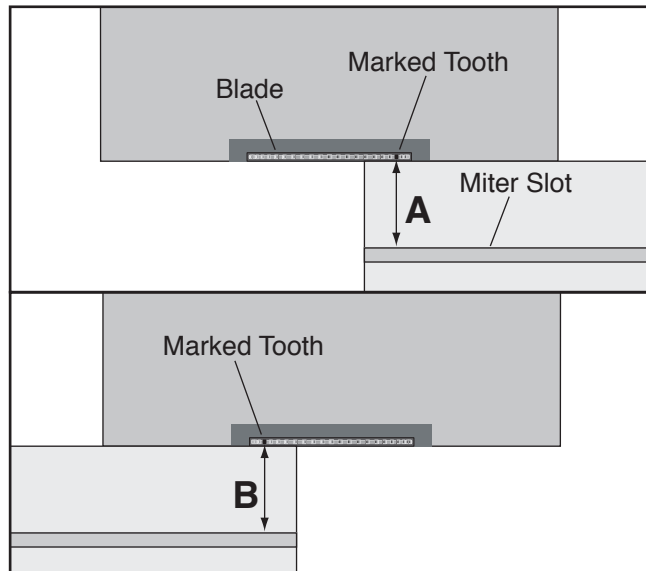

Figure 118. Measuring distance between table and blade.

5. Rotate the blade 180°, move the sliding table all the way forward, and measure the distance between "B" in **Figure 118**.
6. Note the difference between the two positions.
 - If the gap is the same on both sides or the difference is 0.004" or less, no adjustments to the table parallelism need to be made.
 - If the difference is greater than 0.004", then the sliding table parallelism must be adjusted. Proceed to **Step 7**.
7. Loosen the sliding table mounting nuts (see **Figure 119**) at both mounting locations.

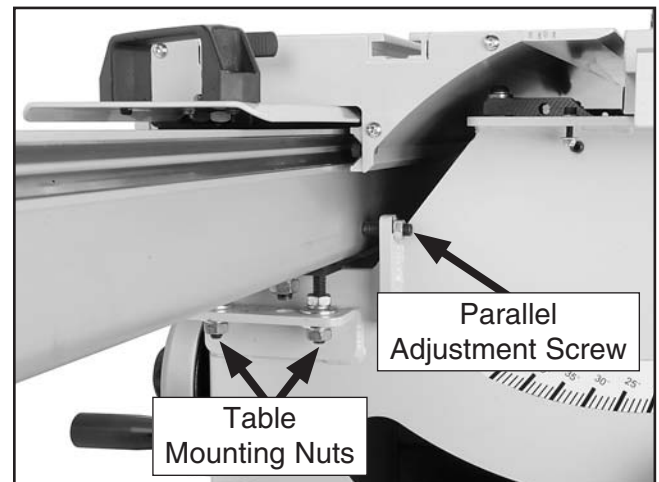

Figure 119. Table parallelism adjustment controls.

8. At the side of the table that needs to move, loosen the hex nut on the parallel adjustment screw.
9. Slowly rotate the parallel adjustment screw (see **Figure 119**) as necessary to move the table. If you move the adjustment screw away from the table, then push the table against the screw before proceeding.
10. Tighten the hex nut on the parallel adjustment screw to secure it in place, then tighten the table mounting nuts. Repeat **Steps 4–6** as necessary until the sliding table is parallel with the blade.



Sliding Table Adjustment

The sliding table features an adjustment bar with bolts that control how easily the sliding table moves across the base (see **Figure 120**). These adjustment bolts are factory set. They can only be accessed by removing the end covers from both ends of the sliding table base and sliding the thin plate out of the way.

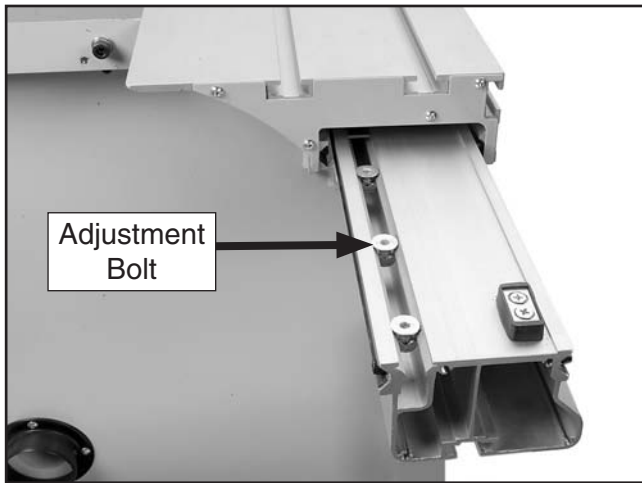

Figure 120. Adjustment bolt access location.

If the adjustment bolts do require adjustments, turning them counterclockwise increases and clockwise decreases pressure against the steel rails. Increasing pressure against the rails reduces table movement slop, which increases accuracy, but makes it harder to slide the table. Decreasing pressure against the rails makes it easier to slide the table, but increases table movement slop, which reduces accuracy.

Adjusting this part of the sliding table correctly is a matter of trial-and-error by making adjustments, moving the sliding table, then making additional adjustments and repeating the process until the sliding table moves as desired. Ideally, the table will move easily but without any slop.

Squaring Miter Fence to Blade

The accuracy of the miter fence angle is dependent on the accuracy of the sliding table parallelism adjustment. As long as the sliding table is adjusted correctly, the miter fence scale will be reasonably accurate. However, if the project requires a high degree of accuracy, we recommend squaring the miter fence to the blade manually with an accurate scale instead of using the miter scale.

To square the miter fence with the blade:

1. DISCONNECT SAW FROM POWER!
2. Move the blade guard up and out of the way, so you have access to the blade.
3. Loosen the miter fence lock handle, so the fence angle can be adjusted.
4. Place a square against the blade body (do not touch the blade teeth), and position the fence so it is evenly touching the length of the square, as illustrated in **Figure 121**.

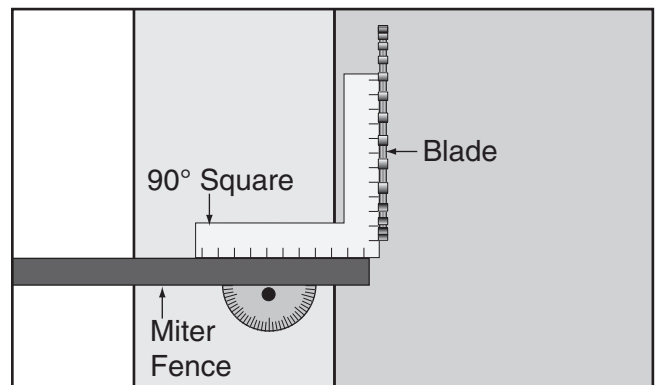

Figure 121. Using a square to adjust the miter fence 90° to the blade.

5. Tighten the miter fence in position. Now you have accurately set the miter gauge square to the blade.



Adjusting Riving Knife Mounting Block

The riving knife must be aligned with the blade when installed. If the riving knife is not aligned with the blade, then the workpiece will be forced sideways during the cut, which will increase the risk of kickback.

The riving knife mounts to a block that can be repositioned to correctly align the riving knife to the blade. The mounting block adjusts by turning the set screws in each corner of the block. **Figure 122** shows the set screws associated with controlling the mounting block position. Have patience when adjusting the mounting block, because it requires trial-and-error to perform with accuracy.

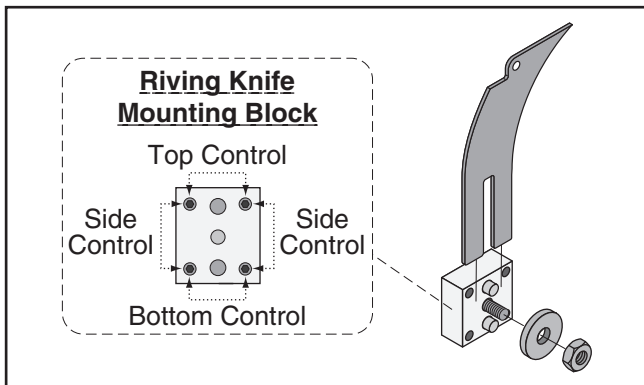

Figure 122. Riving knife mounting block adjustment controls.

All adjustment and alignment positions for the riving knife are covered on **Page 32** in the subsection **Riving Knife Installation & Removal**; the mounting block should not be adjusted unless you have been unable to mount the riving knife as instructed by these procedures.

Tools Needed	Qty
Straightedge	1
Wrench 17mm	1
Hex Wrench 4mm.....	1

To adjust the riving knife mount block:

1. DISCONNECT SAW FROM POWER!
 2. Raise the blade all the way up, move the sliding table to the side, and open the lower blade cover to gain access to the riving knife mounting block.
 3. Loosen the lock nut that secures the riving knife to the mounting block, and remove the riving knife.
 4. Adjust the each pair of set screws that controls the direction required to move the mounting block so the riving knife can be aligned with the blade. Make sure to move both set screws in even increments.
 5. Reinstall the riving knife and check the alignment with the blade. Repeat **Step 4** as necessary until the riving knife is properly aligned to the blade.
- Note:** *If you discover that the riving knife is bent and cannot be properly aligned with the blade, it is possible to bend it into alignment, but make sure that the final result is precisely aligned so the risk of kickback is not increased. If the riving knife is bent, and you cannot easily bend it back into alignment, we recommend replacing it with a new one.*
6. Properly re-install the riving knife as described on **Page 32**, close the blade cover, and move the sliding table back to the center position.



SECTION 9: WIRING

These pages are current at the time of printing. However, in the spirit of improvement, we may make changes to the electrical systems of future machines. Study this section carefully. If there are differences between your machine and what is shown in this section, call Technical Support at (570) 546-9663 for assistance BEFORE making any changes to the wiring on your machine.

WARNING

Wiring Safety Instructions

SHOCK HAZARD. Working on wiring that is connected to a power source is extremely dangerous. Touching electrified parts will result in personal injury including but not limited to severe burns, electrocution, or death. Disconnect the power from the machine before servicing electrical components!

MODIFICATIONS. Modifying the wiring beyond what is shown in the diagram may lead to unpredictable results, including serious injury or fire. This includes the installation of unapproved after-market parts.

WIRE CONNECTIONS. All connections must be tight to prevent wires from loosening during machine operation. Double-check all wires disconnected or connected during any wiring task to ensure tight connections.

CIRCUIT REQUIREMENTS. You MUST follow the requirements at the beginning of this manual when connecting your machine to a power source.

WIRE/COMPONENT DAMAGE. Damaged wires or components increase the risk of serious personal injury, fire, or machine damage. If you notice that any wires or components are damaged while performing a wiring task, replace those wires or components.

MOTOR WIRING. The motor wiring shown in these diagrams is current at the time of printing but may not match your machine. If you find this to be the case, use the wiring diagram inside the motor junction box.















CAPACITORS/INVERTERS. Some capacitors and power inverters store an electrical charge for up to 10 minutes after being disconnected from the power source. To reduce the risk of being shocked, wait at least this long before working on capacitors.

EXPERIENCING DIFFICULTIES. If you are experiencing difficulties understanding the information included in this section, contact our Technical Support at (570) 546-9663.

NOTICE

The photos and diagrams included in this section are best viewed in color. You can view these pages in color at www.grizzly.com.

COLOR KEY

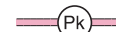
BLACK 	BLUE 	YELLOW 	LIGHT BLUE 
WHITE 	BROWN 	YELLOW GREEN 	BLUE WHITE 
GREEN 	GRAY 	PURPLE 	TURQUOISE 
RED 	ORANGE 	PINK 	



Wiring Diagrams



COLOR KEY

BLACK	
WHITE	
GREEN	
RED	

MAGNETIC SWITCH ASSEMBLY

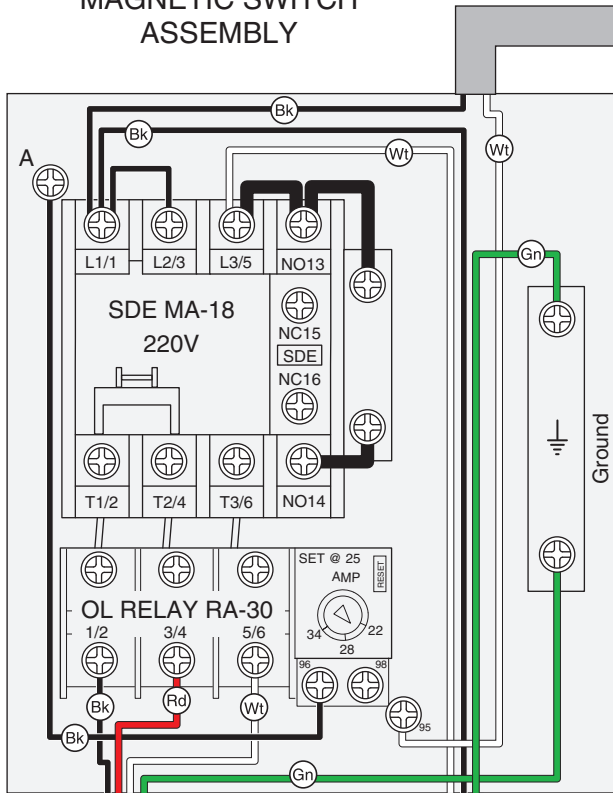

EMERGENCY STOP SWITCH

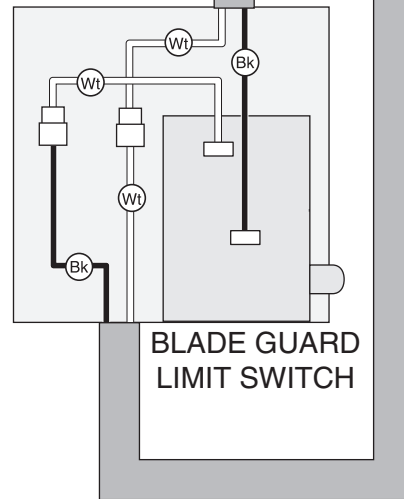
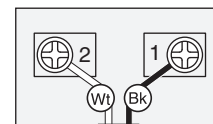

BLADE GUARD LIMIT SWITCH

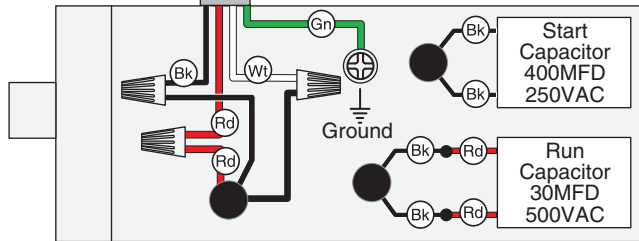

MOTOR 5HP 220V SINGLE-PHASE

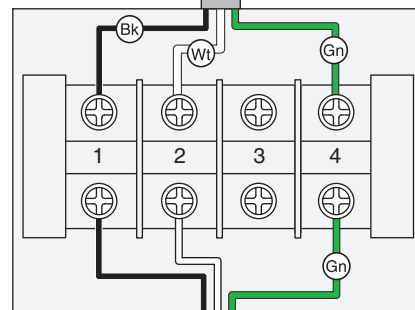

POWER CONNECTION BOX

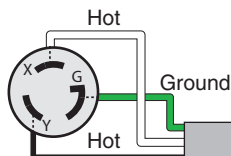

L6-30 PLUG (AS RECOMMENDED)



Electrical Components



Figure 123. Power junction box wiring.

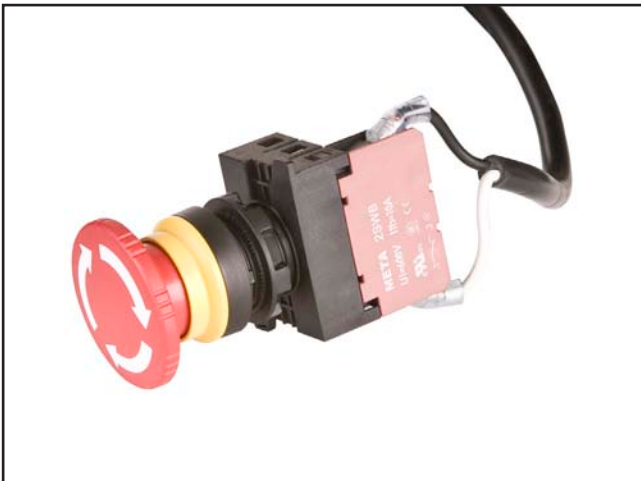

Figure 124. Emergency STOP button wiring.

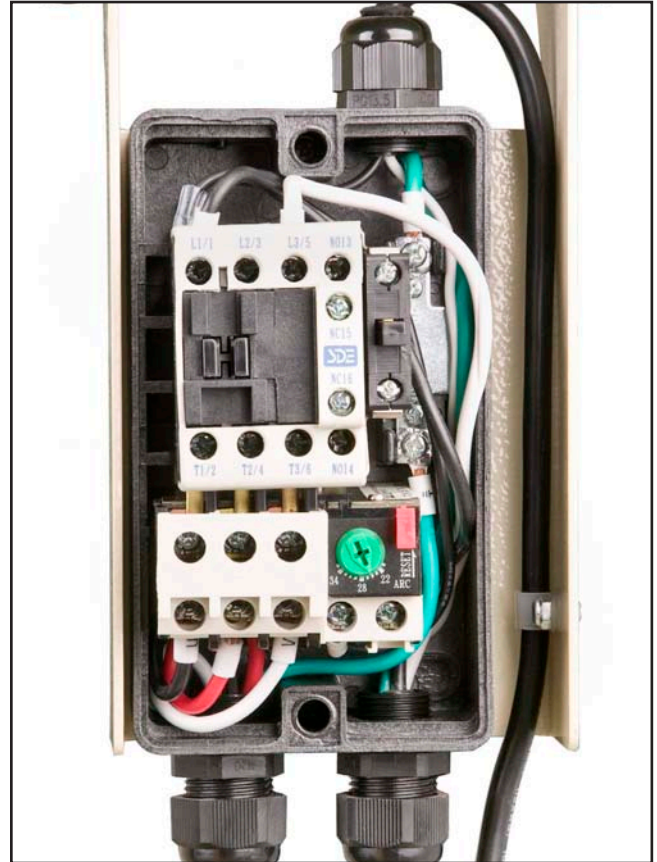
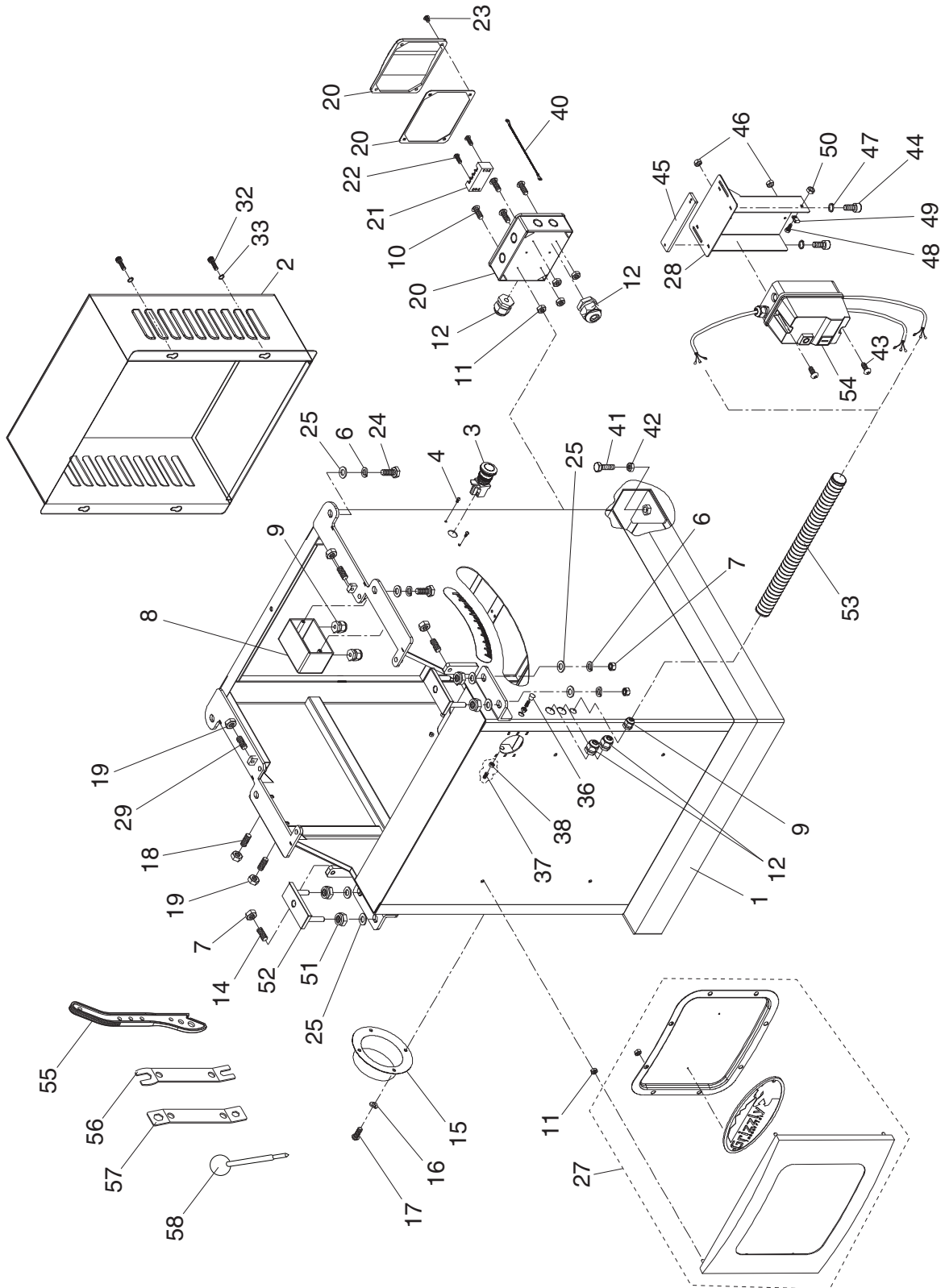

Figure 125. Magnetic switch wiring.

SECTION 10: PARTS

Cabinet



Cabinet Parts List

REF	PART #	DESCRIPTION
1	P0700001	CABINET BASE
2	P0623X0002	MOTOR COVER
3	P0623X0003	EMERGENCY STOP BUTTON
4	PHTEK19M	TAP SCREW M5 X 16
6	PLW06M	LOCK WASHER 10MM
7	PN02M	HEX NUT M10-1.5
8	P0700008	SWITCH BOX
9	P0623X0009	STRAIN RELIEF PG-9
10	PBHS09M	BUTTON HD CAP SCR M6-1 X 12
11	PN01M	HEX NUT M6-1
12	P0700012	STRAIN RELIEF PG-13.5
14	PSS84M	SET SCREW M10-1.5 X 35
15	P0700015	DUST PORT
16	PLW03M	LOCK WASHER 6MM
17	PS11M	PHLP HD SCR M6-1 X 16
18	PSS74M	SET SCREW M8-1.25 X 35
19	PN03M	HEX NUT M8-1.25
20	P0700020	POWER BOX ASSY
21	P0623X0021	TERMINAL BAR 4P
22	PS105M	PHLP HD SCR M3.5-.6 X 20
23	PBHS37M	BUTTON HD CAP SCR M5-.8 X 35
24	PB01M	HEX BOLT M10-1.5 X 30
25	PW04M	FLAT WASHER 10MM
27	P0700027	FRONT PANEL
28	P0700028	SWITCH SEAT

REF	PART #	DESCRIPTION
29	PSS74M	SET SCREW M8-1.25 X 35
32	PCAP11M	CAP SCREW M8-1.25 X 16
33	PLW04M	LOCK WASHER 8MM
36	P0700036	PLUG M10-1.5
37	PSS105M	SET SCREW M12-1.75 X 35
38	PN09M	HEX NUT M12-1.75
40	P0700040	GROUND WIRE 16AWG X 100MM
41	PB35M	HEX BOLT M12-1.75 X 40
42	PN09M	HEX NUT M12-1.75
43	PS56M	PHLP HD SCR M4-.7 X 16
44	PCAP24M	CAP SCREW M5-.8 X 16
45	P0700045	LOCATE PLATE
46	PN04M	HEX NUT M4-.7
47	PW02M	FLAT WASHER 5MM
48	PCAP33M	CAP SCREW M5-.8 X 12
49	P0700049	CORD CLAMP 3/8"
50	PN06M	HEX NUT M5-.8
51	PLN05M	LOCK NUT M10-1.5
52	P0700052	LOCATE BLOCK
53	P0700053	CONDUIT 32 X 40
54	P0700054	MAG SWITCH ASSY
55	P0700055	PUSH STICK
56	P0700056	ARBOR WRENCH 17MM
57	P0700057	ARBOR WRENCH 19/22MM
58	P0700058	ARBOR LOCK TOOL



Handwheels

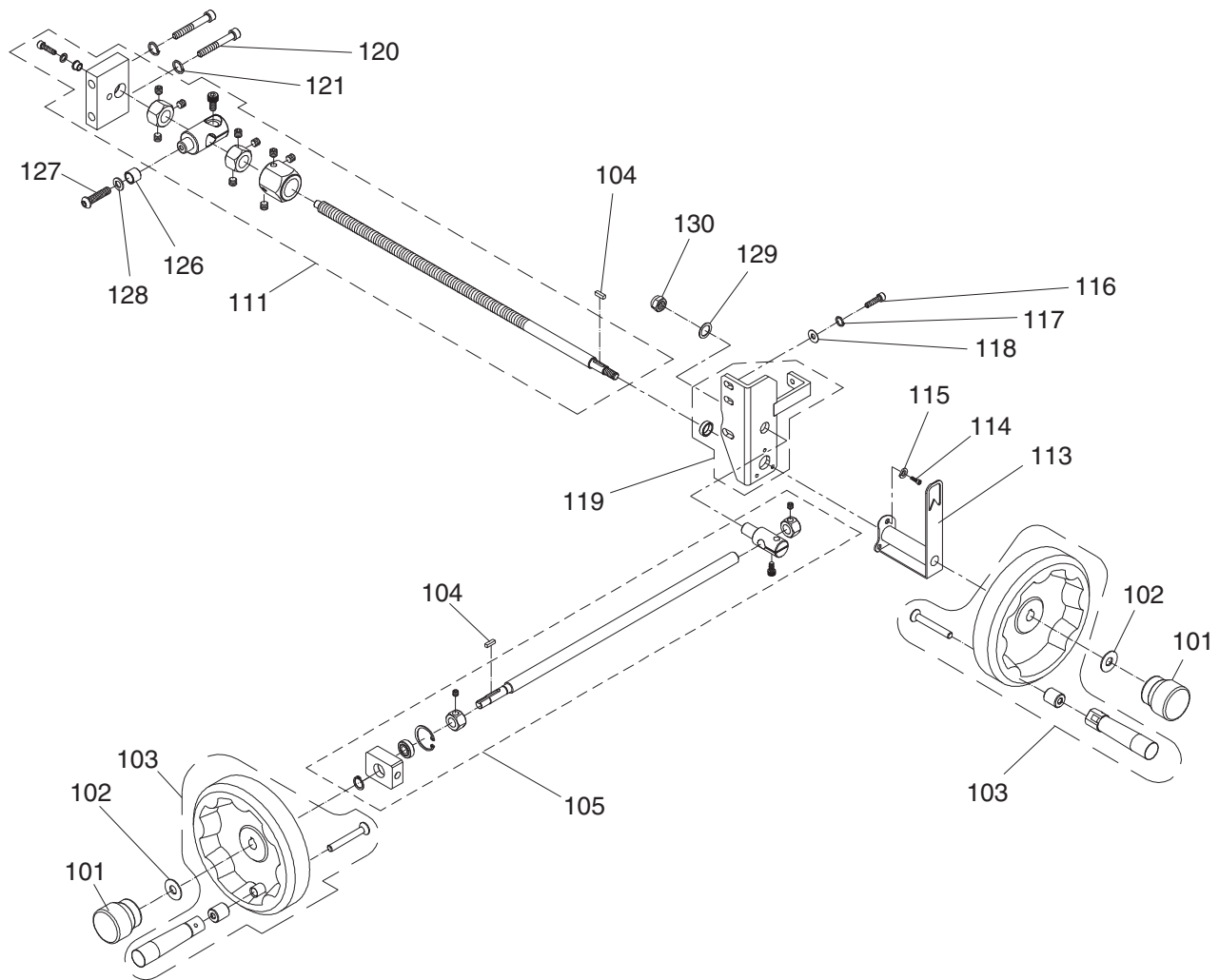

REF	PART #	DESCRIPTION
101	P0623X0601	HANDWHEEL LOCK KNOB M10-1.5
102	P0623X0641	DISC WASHER 10 X 20
103	P0700103	HANDWHEEL ASSY
104	PK34M	KEY 5 X 5 X 20
105	P0700105	TILT ADJ SHAFT ASSY
111	P0700111	ELEVATION LEADSCREW ASSY
113	P0700113	POINTER
114	PCAP04M	CAP SCREW M6-1 X 10
115	PLW03M	LOCK WASHER 6MM
116	PCAP14M	CAP SCREW M8-1.25 X 20

REF	PART #	DESCRIPTION
117	PLW04M	LOCK WASHER 8MM
118	PW01M	FLAT WASHER 8MM
119	P0700119	SUPPORT BRACKET ASSY
120	PCAP05M	CAP SCREW M8-1.25 X 50
121	PLW04M	LOCK WASHER 8MM
126	P0700126	BUSHING
127	PCAP04M	CAP SCREW M6-1 X 10
128	PW03M	FLAT WASHER 6MM
129	P0700129	COPPER WASHER 16MM X 0.2T
130	PLN07M	LOCK NUT M16-2



Main Motor

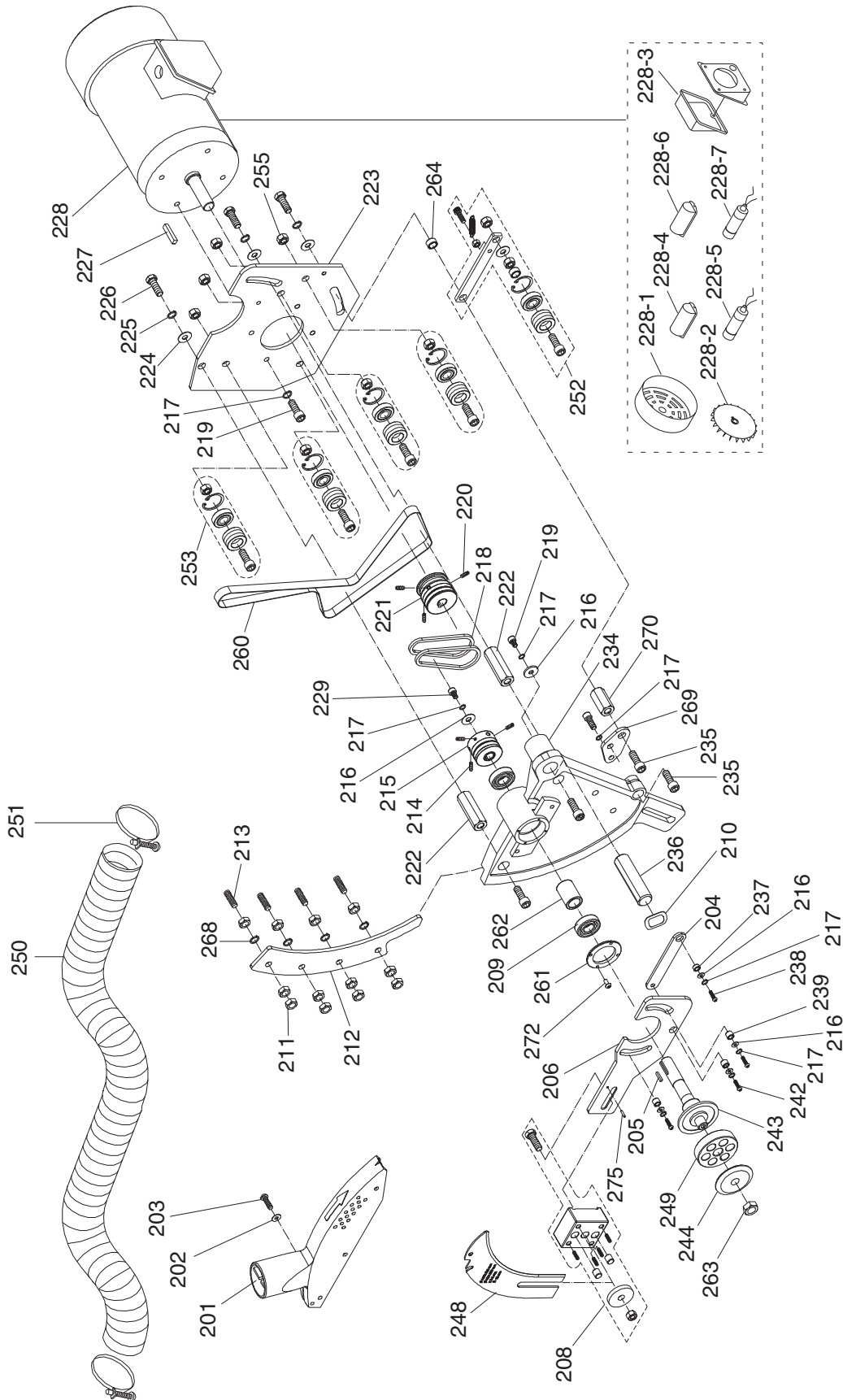

Main Motor Parts List

REF	PART #	DESCRIPTION
201	P0623X0201	BLADE GUARD COVER
202	PWF08M	FENDER WASHER 8MM
203	PBHS07M	BUTTON HD CAP SCR M8-1.25 X 40
204	P0623X0208	LINK PLATE
205	PK34M	KEY 5 X 5 X 20
206	P0623X0206	LOCATING BLOCK
208	P0623X0204	MOUNTING BLOCK ASSY
209	P6004-2RS	BALL BEARING 6004-2RS
210	P0700210	WAVE WASHER 26 X 34
211	PN02M	HEX NUT M10-1.5
212	P0623X0212	GIB PLATE
213	PSS86M	SET SCREW M10-1.5 X 45
214	PSS05M	SET SCREW M5-.8 X 10
215	P0700215	ARBOR PULLY 60HZ
216	PWF08M	FENDER WASHER 8MM
217	PLW04M	LOCK WASHER 8MM
218	P0700218	V-BELT M-20 3L200
219	PCAP14M	CAP SCREW M8-1.25 X 20
220	PSS06M	SET SCREW M8-1.25 X 16
221	P0700221	MOTOR PULLEY
222	P0700222	COUPLING NUT M12-1.75
223	P0623X0223	MAIN MOTOR MOUNTING PLATE
224	PW06M	FLAT WASHER 12MM
225	PLW05M	LOCK WASHER 12MM
226	PB25M	HEX BOLT M12-1.75 X 25
227	PK28M	KEY 7 X 7 X 30
228	P0623X228	MAIN MOTOR 5HP 220V 60HZ 1PH
228-1	P0623X228-1	MOTOR FAN COVER
228-2	P0623X228-2	MOTOR FAN
228-3	P0623X228-3	JUNCTION BOX
228-4	P0623X228-4	CAPACITOR COVER

REF	PART #	DESCRIPTION
228-5	P0623X228-5	S CAPACITOR 400M 250V 1-3/4 X 3-1/2
228-6	P0623X228-6	CAPACITOR COVER
228-7	P0623X228-7	R CAPACITOR 30M 500V 1-1/2 X 3-3/8
229	PCAP14M	CAP SCREW M8-1.25 X 20
234	P0700234	ARBOR HOUSING
235	PCAP77M	CAP SCREW M12-1.75 X 30
236	P0700236	SHAFT
237	P0623X0237	BUSHING
238	PBHS22M	BUTTON HD CAP SCR M8-1.25 X 20
239	P0700239	BUSHING
242	PBHS03M	BUTTON HD CAP SCR M8-1.25 X 16
243	P0623X0243	MAIN ARBOR CSA
244	P0623X0244	ARBOR FLANGE CSA
248	P0623X0248	RIVING KNIFE
249	P0623X0249	ARBOR SPACER BLOCK
250	P0623X0250	HOSE 3" X 60CM
251	P0623X0251	HOSE CLAMP 3-1/4"
252	P0700252	PIVOTING IDLER PULLEY ASSY
253	P0700253	IDLER PULLEY ASSY
255	PN09M	HEX NUT M12-1.75
260	P0700260	FLAT BELT 15 X 1140MM
261	P0623X0261	PLATE
262	P0623X0262	BUSHING
263	P0700263	ARBOR NUT 5/8-16 X 12 LH
264	P0623X0264	BUSHING
268	PLW06M	LOCK WASHER 10MM
269	P0700269	ATTACHMENT PLATE
270	P0700270	COUPLING NUT M12-1.75
272	PBHS06M	BUTTON HD CAP SCR M5-.8 X 12
275	PRP61M	ROLL PIN 3 X 12



Blade Housing

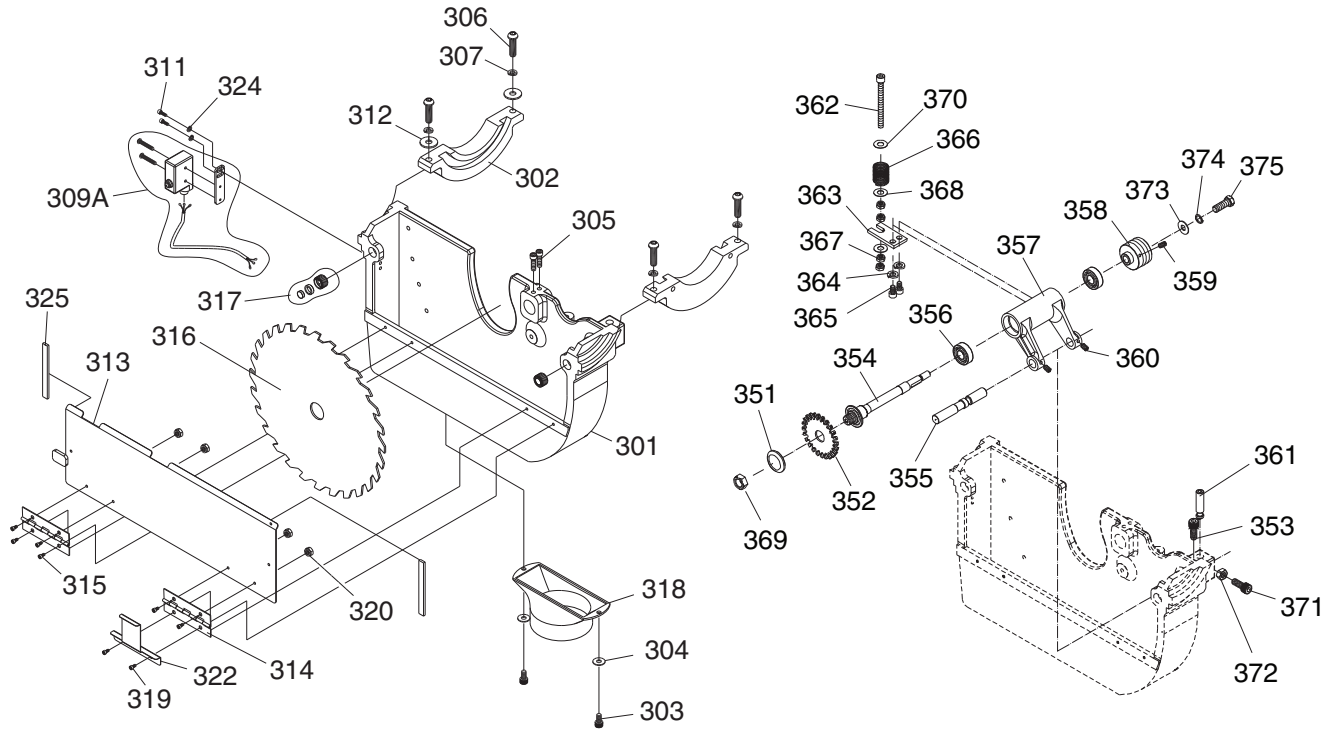

REF	PART #	DESCRIPTION
301	P0623X0101	CHANNEL BASE
302	P0623X0102	TRUNNION BRACKET
303	PCAP04M	CAP SCREW M6-1 X 10
304	PLW03M	LOCK WASHER 6MM
305	PCAP11M	CAP SCREW M8-1.25 X 16
306	PBHS04M	BUTTON HD CAP SCR M8-1.25 X 35
307	PLW04M	LOCK WASHER 8MM
309A	P0700309A	BLADE COVER SWITCH ASSY
311	PSB50M	CAP SCREW M5-.8 X 10
312	PW01M	FLAT WASHER 8MM
313	P0623X0113	BLADE GUARD PLATE
314	P0623X0114	HINGE
315	PS05M	PHLP HD SCR M5-.8 X 8
316	P0700316	SAW BLADE 10" X 5/8 X 40T
317	P0623X0117	MAGNET ASSEMBLY
318	P0623X0118	BLADE SHROUD DUST PORT
319	PS40M	PHLP HD SCR M5-.8 X 16
320	PLN02M	LOCK NUT M5-.8
322	P0700322	KEEPER PLATE
324	P0700324	LOCK WASHER 5MM
325	P0700325	PAD
351	P0623X0701	ARBOR FLANGE
352	P0623X0702	SCORING SAW BLADE CSA 22MM

REF	PART #	DESCRIPTION
353	PCAP14M	CAP SCREW M8-1.25 X 20
354	P0623X0704	SCORING ARBOR SHAFT 22MM
355	P0623X0705	PIVOT SHAFT
356	P6202-2RS	BALL BEARING 6202-2RS
357	P0623X0707	REGULATOR
358	P0623X0708	SCORING PULLEY 60HZ
359	PSS02M	SET SCREW M6-1 X 6
360	PSS02M	SET SCREW M6-1 X 6
361	P0623X0711	ADJUST SHAFT
362	PCAP157M	CAP SCREW M8-1.25 X 100
363	P0623X0713	PLATE
364	PLW04M	LOCK WASHER 8MM
365	PCAP31M	CAP SCREW M8-1.25 X 25
366	P0623X0716	LOCK
367	PLN04M	LOCK NUT M8-1.25
368	PW04M	FLAT WASHER 10MM
369	PN09M	HEX NUT M12-1.75
370	PW04M	FLAT WASHER 10MM
371	PCAP02M	CAP SCREW M6-1 X 20
372	PN01M	HEX NUT M6-1
373	PWF06M	FENDER WASHER 6MM
374	PLW03M	LOCK WASHER 6MM
375	P06990514	HEX BOLT M6-1 X 16 LH



Tables

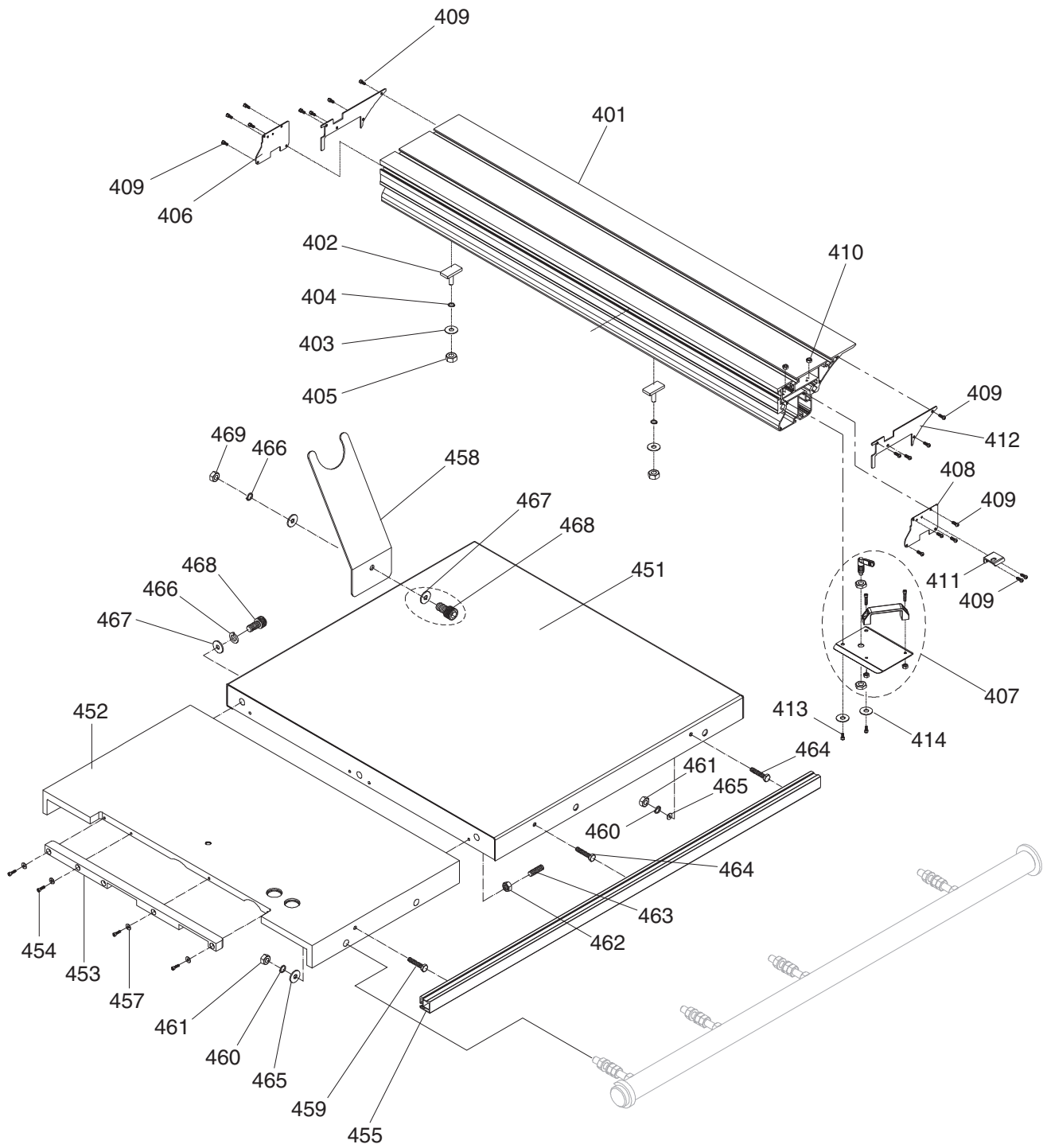

Tables Parts List

REF	PART #	DESCRIPTION
401	P0700401	SLIDING TABLE SET 1000 X 316MM
402	P0623X0302	T-SCREW M12-1.75 X 35
403	PW06M	FLAT WASHER 12MM
404	PLW05M	LOCK WASHER 12MM
405	PN09M	HEX NUT M12-1.75
406	P0623X0319	SLIDING TABLE BASE END PLATE
407	P0700407	PUSH/PULL HANDLE ASSY
408	P0623X0320	SLIDING TABLE BASE END PLATE
409	PBHS09M	BUTTON HD CAP SCR M6-1 X 12
410	PN01M	HEX NUT M6-1
411	P0700411	LOCK BRACKET
412	P0700412	SLIDING TABLE END COVER
413	PCAP115M	BUTTON HD CAP SCR M6-1 X 16
414	PW03M	FLAT WASHER 6MM
451	P0623X0401	EXTENSION TABLE
452	P0623X0402	CAST IRON TABLE

REF	PART #	DESCRIPTION
453	P0623X0403	TABLE INSERT
454	PCAP15M	CAP SCREW M5-.8 X 20
455	P0623X0405	RIP FENCE SCALE
457	PW02M	FLAT WASHER 5MM
458	P0623X0430	DUST HOSE SUPPORT
459	PB10M	HEX BOLT M6-1 X 25
460	PLW03M	LOCK WASHER 6MM
461	PN01M	HEX NUT M6-1
462	PN03M	HEX NUT M8-1.25
463	PSS21M	SET SCREW M8-1.25 X 25
464	PB83M	HEX BOLT M6-1 X 16
465	PW03M	FLAT WASHER 6MM
466	PLW06M	LOCK WASHER 10MM
467	PW04M	FLAT WASHER 10MM
468	PCAP64M	CAP SCREW M10-1.5 X 25
469	PLN05M	LOCK NUT M10-1.5



Fence

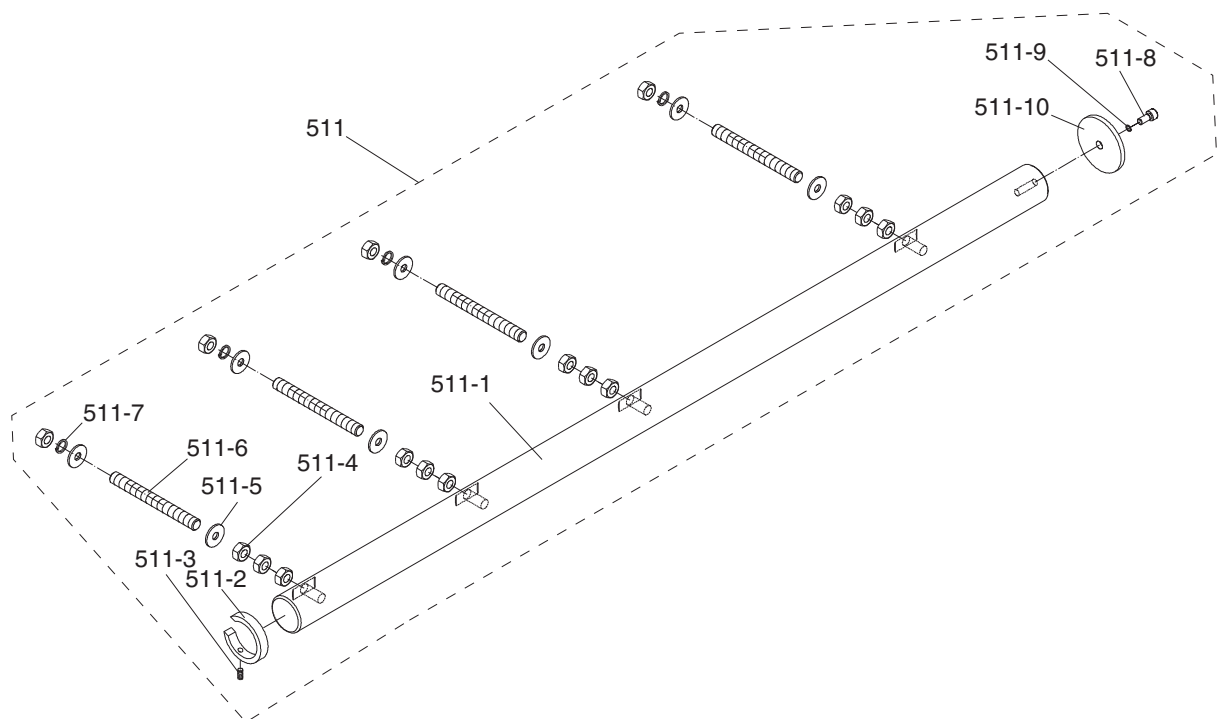
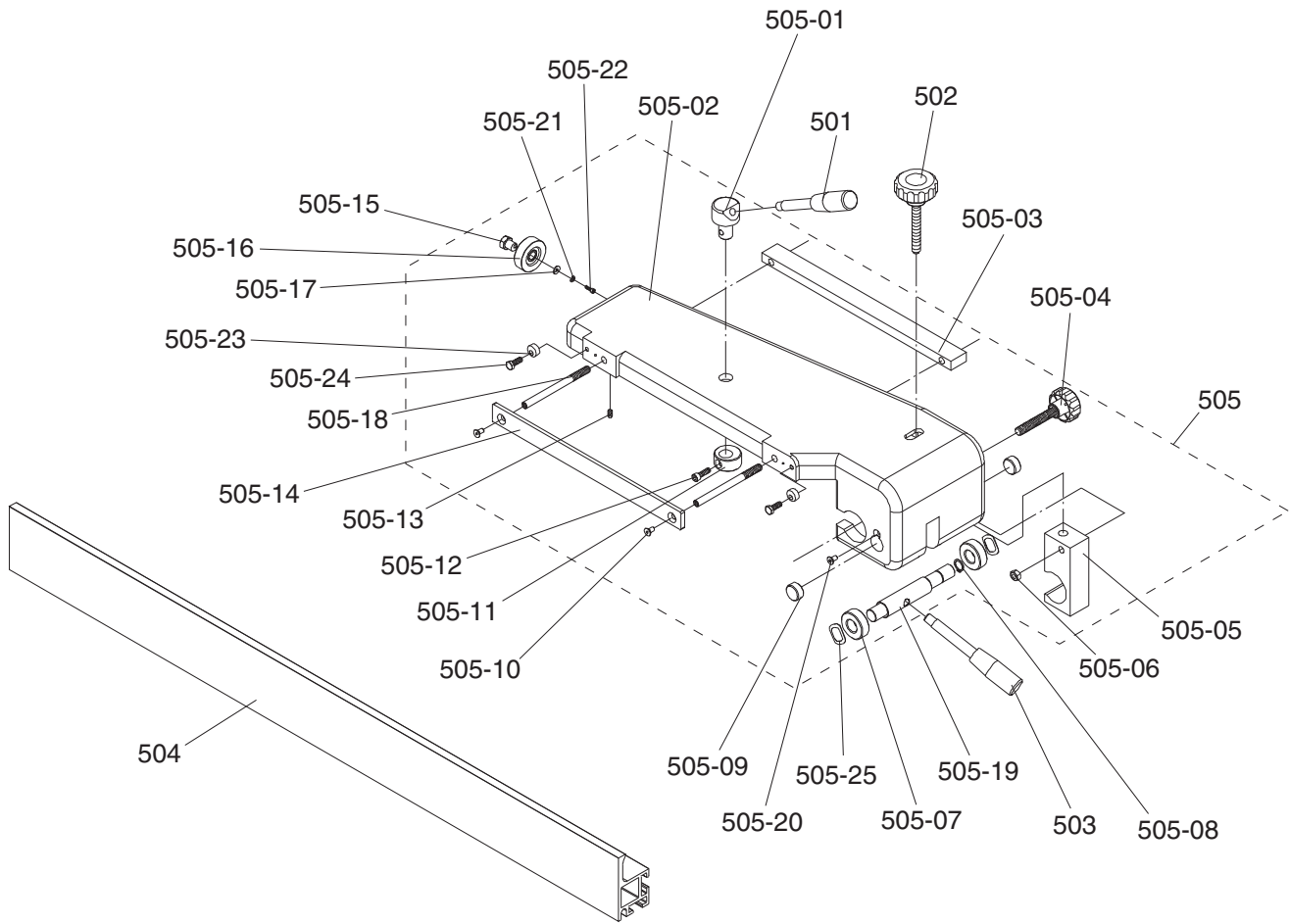

Fence Parts List

REF	PART #	DESCRIPTION
501	P0700501	HANDLE
502	P0700502	KNOB SCREW M10-1.5 X 70
503	P0700501	HANDLE
504	P0700504	RIP FENCE
505	P0700505	RIP FENCE BASE ASSY
505-01	P0700505-01	ROTATE SHAFT
505-02	P0700505-02	RIP FENCE HOUSING
505-03	P0700505-03	LOCATE PLATE
505-04	P0700505-04	MICRO ADJUSTING KNOB
505-05	P0700505-05	LOCATE BLOCK
505-06	PLN05M	LOCK NUT M10-1.5
505-07	P0700505-07	LOCK RING
505-08	PR05M	EXT RETAINING RING 15MM
505-09	P0700505-09	PLUG
505-10	PFH05M	FLAT HD SCR M5-.8 X 12
505-11	P0700505-11	CAM
505-12	PCAP11M	CAP SCREW M8-1.25 X 16
505-13	PSS05M	SET SCREW M5-.8 X 10
505-14	P0700505-14	CLAMP PLATE
505-15	P0700505-15	ECCENTRIC SHAFT
505-16	P0700505-16	PLASTIC BALL BEARING

REF	PART #	DESCRIPTION
505-17	PW03M	FLAT WASHER 6MM
505-18	P0700505-18	CLAMP PLATE STUD
505-19	P0700505-19	FENCE LOCK SHAFT
505-20	PFH30M	FLAT HD SCR M5-.8 X 8
505-21	PLW03M	LOCK WASHER 6MM
505-22	PCAP04M	CAP SCREW M6-1 X 10
505-23	P0700505-23	ECCENTRIC RING
505-24	PB83M	HEX BOLT M6-1 X 16
505-25	P0700505-25	WAVE WASHER 24 X 31
511	P0700511	ROUND RAIL ASSY
511-1	P0700511-1	ROUND RAIL
511-2	P0700511-2	RING STOP
511-3	PSS01M	SET SCREW M6-1 X 10
511-4	PN09M	HEX NUT M12-1.75
511-5	PW01	FLAT WASHER 1/2
511-6	P0700511-6	STUD M12-1.75
511-7	PLW05M	LOCK WASHER 12MM
511-8	PCAP11M	CAP SCREW M8-1.25 X 16
511-9	PLW04M	LOCK WASHER 8MM
511-10	P0700511-10	END WASHER



Miter Gauge

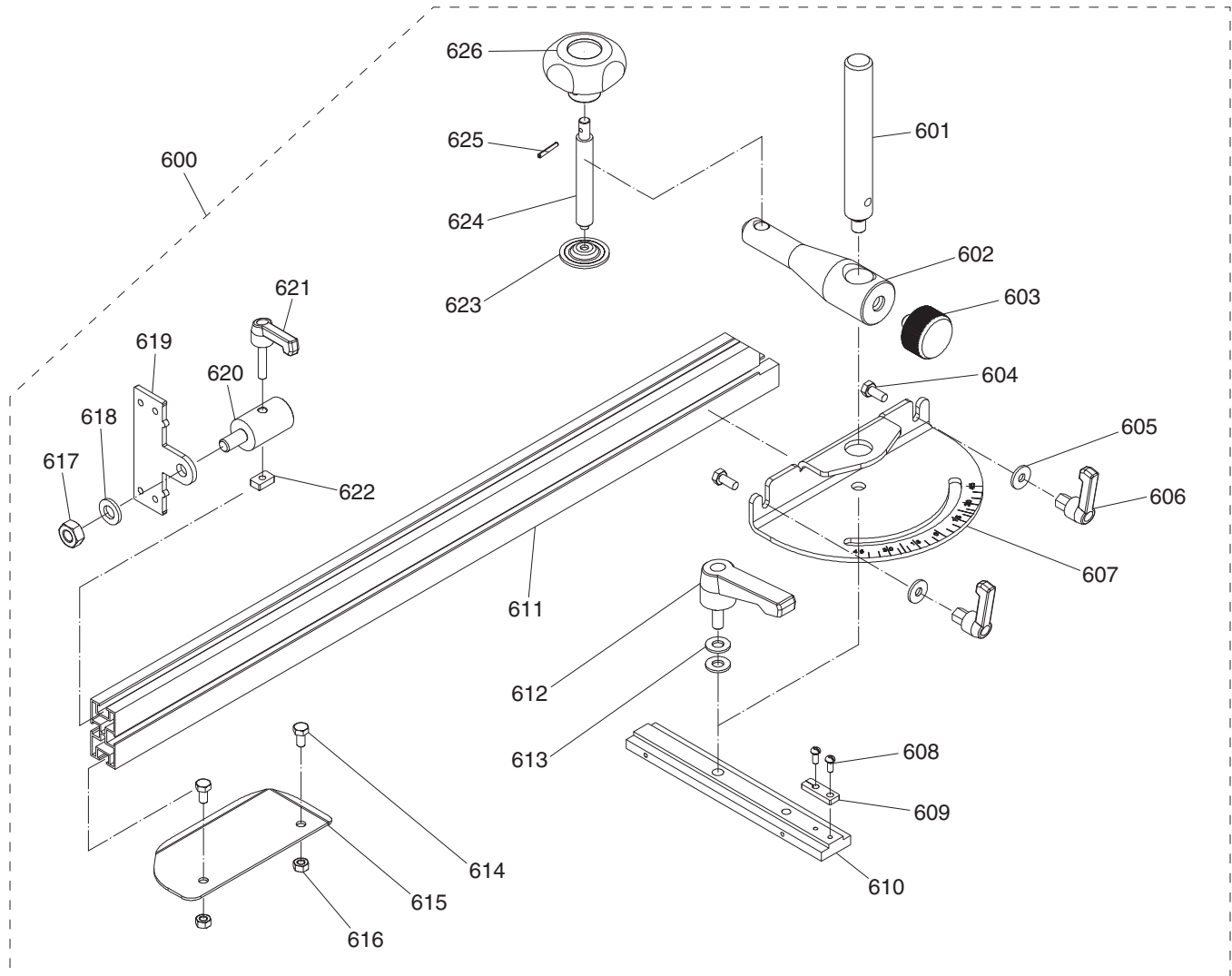

REF	PART #	DESCRIPTION
600	P0700600	MITER GAUGE ASSY
601	P0700601	FIXED SHAFT
602	P0700602	CLAMP BRACKET POST
603	P0700603	CLAMP ADJUSTMENT KNOB
604	PCAP01M	CAP SCREW M6-1 X 16
605	PW03M	FLAT WASHER 6MM
606	P0700606	ADJUSTMENT HANDLE M6-1
607	P0700607	MITER GAUGE BODY
608	PS38M	PHLP HD SCR M4-.7 X 10
609	P0700609	POINTER
610	P0700610	MITER T-SLOT BAR
611	P0700611	MITER FENCE
612	P0700612	ADJUSTMENT HANDLE
613	PW01M	FLAT WASHER 8MM

REF	PART #	DESCRIPTION
614	PB02M	HEX BOLT M6-1 X 12
615	P0700615	FIXED PLATE
616	PN01M	HEX NUT M6-1
617	PLN05M	LOCK NUT M10-1.5
618	PW04M	FLAT WASHER 10MM
619	P0700619	FLIP STOP
620	P0700620	FIXED SHAFT
621	P0623X1012	ADJUSTMENT HANDLE M6 X 30
622	PSN02M	SQUARE NUT M6-1
623	P0700623	CLAMP FOOT
624	P0700624	CLAMP SHAFT
625	PRP42M	ROLL PIN 3 X 20
626	P0700626	PLASTIC KNOB



Labels & Miscellaneous

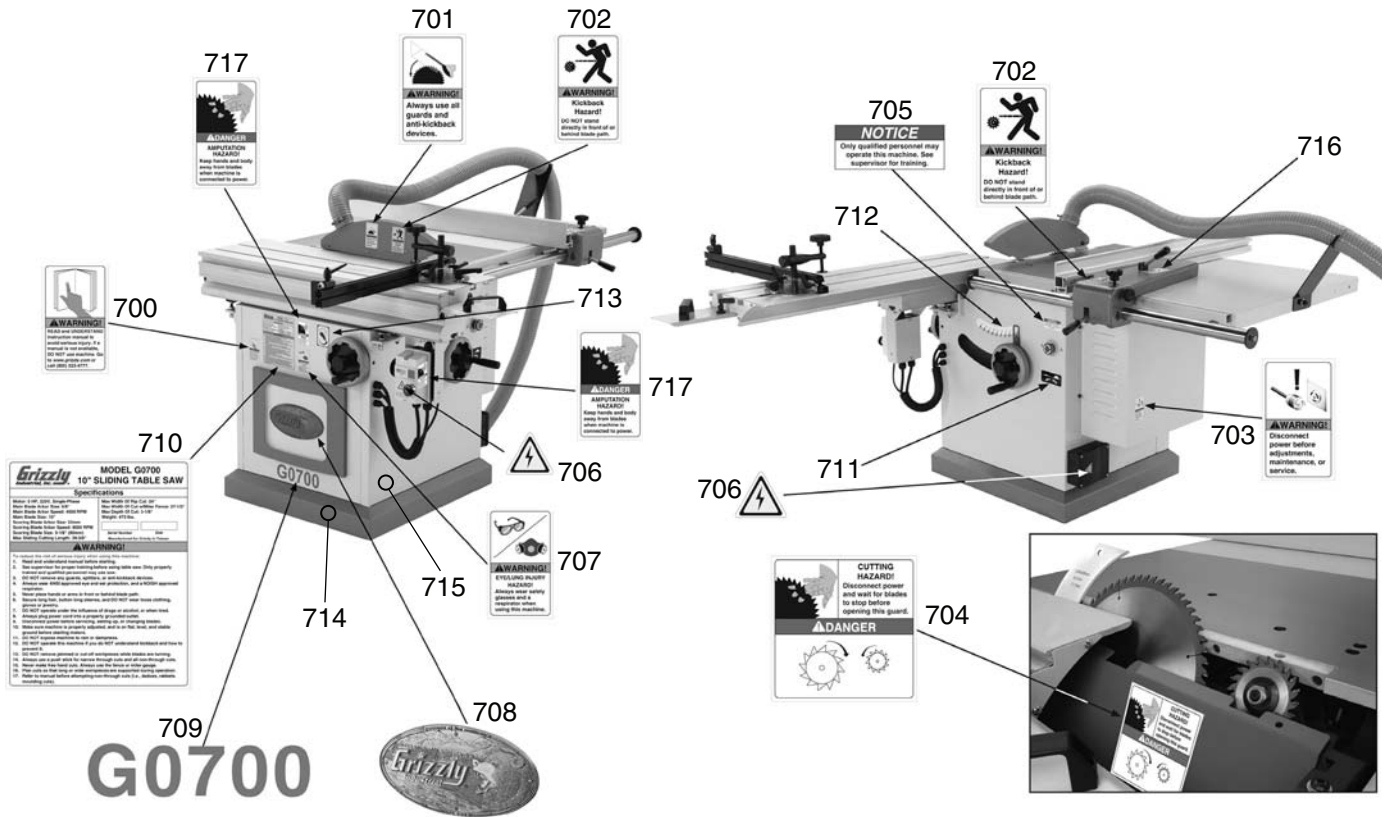

REF	PART #	DESCRIPTION
700	PLABEL-12A	READ MANUAL LABEL
701	P0623X1202	TABLE SAW BLADE GUARD LABEL
702	P0623X1203	KICKBACK HAZARD LABEL
703	PLABEL-33	DISCONNECT POWER LABEL
704	P0623X1205	BLADE GUARD DANGER LABEL
705	P0623X1206	QUALIFIED PERSONNEL LABEL
706	PLABEL-14	ELECTRICITY LABEL
707	PLABEL-37	GLASSES/RESPIRATOR LABEL
708	G8588	GRIZZLY NAMEPLATE-SMALL

REF	PART #	DESCRIPTION
709	P0700709	MODEL NUMBER LABEL
710	P0700710	MACHINE ID LABEL
711	P0623X1212	BLADE TILT LABEL
712	P0623X1213	BLADE TILT SCALE
713	P0623X1214	BLADE ELEVATION LABEL
714	PPAINT-1	GRIZZLY GREEN TOUCH-UP PAINT
715	PPAINT-11	PUTTY TOUCH-UP PAINT
716	P0700716	RIP FENCE LABEL
717	P0623X1205	BLADE GUARD DANGER LABEL

WARNING

Safety labels warn about machine hazards and ways to prevent injury. The owner of this machine **MUST** maintain the original location and readability of the labels on the machine. If any label is removed or becomes unreadable, **REPLACE** that label before using the machine again. Contact Grizzly at (800) 523-4777 or www.grizzly.com to order new labels.





Grizzly WARRANTY CARD
Industrial, Inc.

Name _____
 Street _____
 City _____ State _____ Zip _____
 Phone # _____ Email _____ Invoice # _____
 Model # _____ Order # _____ Serial # _____

*The following information is given on a voluntary basis. It will be used for marketing purposes to help us develop better products and services. **Of course, all information is strictly confidential.***

1. How did you learn about us?

Advertisement Friend Catalog
 Card Deck Website Other:

2. Which of the following magazines do you subscribe to?

<input type="checkbox"/> Cabinetmaker & FDM	<input type="checkbox"/> Popular Science	<input type="checkbox"/> Wooden Boat
<input type="checkbox"/> Family Handyman	<input type="checkbox"/> Popular Woodworking	<input type="checkbox"/> Woodshop News
<input type="checkbox"/> Hand Loader	<input type="checkbox"/> Precision Shooter	<input type="checkbox"/> Woodsmith
<input type="checkbox"/> Handy	<input type="checkbox"/> Projects in Metal	<input type="checkbox"/> Woodwork
<input type="checkbox"/> Home Shop Machinist	<input type="checkbox"/> RC Modeler	<input type="checkbox"/> Woodworker West
<input type="checkbox"/> Journal of Light Cont.	<input type="checkbox"/> Rifle	<input type="checkbox"/> Woodworker's Journal
<input type="checkbox"/> Live Steam	<input type="checkbox"/> Shop Notes	<input type="checkbox"/> Other:
<input type="checkbox"/> Model Airplane News	<input type="checkbox"/> Shotgun News	
<input type="checkbox"/> Old House Journal	<input type="checkbox"/> Today's Homeowner	
<input type="checkbox"/> Popular Mechanics	<input type="checkbox"/> Wood	

3. What is your annual household income?

\$20,000-\$29,000 \$30,000-\$39,000 \$40,000-\$49,000
 \$50,000-\$59,000 \$60,000-\$69,000 \$70,000+

4. What is your age group?

20-29 30-39 40-49
 50-59 60-69 70+

5. How long have you been a woodworker/metalworker?

0-2 Years 2-8 Years 8-20 Years 20+ Years

6. How many of your machines or tools are Grizzly?

0-2 3-5 6-9 10+

7. Do you think your machine represents a good value? Yes No

8. Would you recommend Grizzly Industrial to a friend? Yes No

9. Would you allow us to use your name as a reference for Grizzly customers in your area?

Note: *We never use names more than 3 times.* Yes No

10. Comments: _____

CUT ALONG DOTTED LINE

FOLD ALONG DOTTED LINE



Place Stamp Here



GRIZZLY INDUSTRIAL, INC.
P.O. BOX 2069
BELLINGHAM, WA 98227-2069



FOLD ALONG DOTTED LINE

Send a Grizzly Catalog to a friend:

Name _____
Street _____
City _____ State _____ Zip _____

TAPE ALONG EDGES--PLEASE DO NOT STAPLE

WARRANTY AND RETURNS

Grizzly Industrial, Inc. warrants every product it sells for a period of **1 year** to the original purchaser from the date of purchase. This warranty does not apply to defects due directly or indirectly to misuse, abuse, negligence, accidents, repairs or alterations or lack of maintenance. This is Grizzly's sole written warranty and any and all warranties that may be implied by law, including any merchantability or fitness, for any particular purpose, are hereby limited to the duration of this written warranty. We do not warrant or represent that the merchandise complies with the provisions of any law or acts unless the manufacturer so warrants. In no event shall Grizzly's liability under this warranty exceed the purchase price paid for the product and any legal actions brought against Grizzly shall be tried in the State of Washington, County of Whatcom.

We shall in no event be liable for death, injuries to persons or property or for incidental, contingent, special, or consequential damages arising from the use of our products.

To take advantage of this warranty, contact us by mail or phone and give us all the details. We will then issue you a "Return Number," which must be clearly posted on the outside as well as the inside of the carton. We will not accept any item back without this number. Proof of purchase must accompany the merchandise.

The manufacturers reserve the right to change specifications at any time because they constantly strive to achieve better quality equipment. We make every effort to ensure that our products meet high quality and durability standards and we hope you never need to use this warranty.

Please feel free to write or call us if you have any questions about the machine or the manual.

Thank you again for your business and continued support. We hope to serve you again soon.

grizzly.com®

TOOL WEBSITE

Buy Direct and Save with Grizzly® – Trusted, Proven and a Great Value!
~Since 1983~

*Visit Our Website Today For
Current Specials!*

**ORDER
24 HOURS A DAY!
1-800-523-4777**

